



Reissued February 2023

Revised September 2024

This report is subject to renewal February 2025.

www.icc-es.org | (800) 423-6587 | (562) 699-0543

A Subsidiary of the International Code Council®

DIVISION: 03 00 00—CONCRETE
Section: 03 15 19—Cast-in Concrete Anchors
Section: 03 16 00—Concrete Anchors

REPORT HOLDER:

HILTI, INC.

EVALUATION SUBJECT:

HILTI KCC-WF, KCC-MD, KCCM-WF, KCCM-MD, KCM-WF, KCM-PD, AND KCM-MD HEADED CAST-IN SPECIALTY INSERTS IN CRACKED AND UNCRACKED CONCRETE

1.0 EVALUATION SCOPE

Compliance with the following codes:

- 2024, 2021, 2018, and 2015 *International Building Code*® (IBC)
- 2024, 2021, 2018, and 2015 *International Residential Code*® (IRC)

For evaluation for compliance with codes adopted by the Los Angeles Department of Building and Safety (LADBS), see [ESR-4145 LABC and LARC Supplement](#).

Property evaluated:

Structural

2.0 USES

The Hilti KCC-WF, KCCM-WF, KCM-WF and KCM-PD Headed Cast-In Specialty Insert are used as anchorage to resist static, wind, and seismic (Seismic Design Categories A through F) tension and shear loads in cracked and uncracked normal-weight or lightweight concrete having a specified compressive strength, f'_c , of 2,500 psi to 10,000 psi (17.2 MPa to 68.9 MPa).

The Hilti KCC-MD Short Plate (KCC-MD SP), KCC-MD Long Plate (KCC-MD LP), KCCM-MD Short Plate (KCCM-MD SP), KCCM-MD Long Plate (KCCM-MD LP), KCM-MD Short Plate (KCM-MD SP) and KCM-MD Long Plate (KCM-MD LP) Headed Cast-In Specialty Inserts are used as anchorage to resist static, wind, and seismic (Seismic Design Categories A through F) tension and shear loads in the soffit of cracked and uncracked normal-weight concrete and sand-lightweight concrete over metal deck having a specified compressive strength, f'_c , of 3,000 psi to 10,000 psi (20.7 MPa to 68.9 MPa).

There are two models for Hilti KCC-WF. The KCC-WF 3/8 model is used with a threaded rod size of 3/8 inch and the

KCC-WF 1/2 model is used with a threaded rod size of 1/2 inch.

There are two models for KCCM-WF. The KCCM-WF 1/4-3/8 model is used with a threaded rod size of 1/4 inch or 3/8 inch. The KCCM WF 3/8-1/2 is used with a threaded rod size of 3/8 inch or 1/2 inch

There are six fractional models and one metric model for Hilti KCM-WF. The KCM-WF-1/4-3/8 model is used with a threaded rod size of 1/4 inch or 3/8 inch; the KCM-WF-1/4-3/8-1/2 model is used with a threaded rod size of 1/4 inch, 3/8 inch or 1/2 inch; the KCM-WF-3/8-1/2 model is used with a threaded rod size of 3/8 inch or 1/2 inch; the KCM-WF-3/8-1/2-5/8 model is used with a threaded rod size of 3/8 inch, 1/2 inch, or 5/8 inch; the KCM-WF-3/8-1/2-5/8-3/4 model is used with a threaded rod size of 3/8 inch, 1/2 inch, 5/8 inch, or 3/4 inch; the KCM-WF-5/8-3/4 model is used with a threaded rod size of 5/8 inch or 3/4 inch, the KCM-WF M10-M12 is used with threaded rod size of 10 mm or 12 mm.

There are four models for Hilti KCM-PD. The KCM-PD-1/4-3/8 model is used with a threaded rod size of 1/4 inch or 3/8 inch; the KCM-PD-1/4-3/8-1/2 is used with a threaded rod size of 1/4 inch, 3/8 inch or 1/2 inch, the KCM-PD-3/8-1/2-5/8 model is used with a threaded rod size of 3/8 inch, 1/2 inch, or 5/8 inch; the KCM-PD-3/8-1/2-5/8-3/4 model is used with a threaded rod size of 3/8 inch, 1/2 inch, 5/8 inch, or 3/4 inch.

There are two models for Hilti KCC-MD SP. The KCC-MD SP 3/8 model is used with a threaded rod size of 3/8 inch and the KCC-MD SP 1/2 model is used with a threaded rod size of 1/2 inch.

There are two models for KCCM-MD SP. The KCCM-MD SP 1/4-3/8 model is used with a threaded rod size of 1/4 inch or 3/8 inch. The KCCM-MD SP 3/8-1/2 is used with a threaded rod size of 3/8 inch or 1/2 inch.

There are two models for Hilti KCC-MD LP. The KCC-MD LP 3/8 model is used with a threaded rod size of 3/8 inch and the KCC-MD LP 1/2 model is used with a threaded rod size of 1/2 inch.

There are two models for KCCM-MD LP. The KCCM-MD LP 1/4-3/8 model is used with a threaded rod size of 1/4 inch or 3/8 inch. The KCCM-MD LP 3/8-1/2 is used with a threaded rod size of 3/8 inch or 1/2 inch.

There are 5 models for Hilti KCM-MD SP. The KCM-MD SP 1/4-3/8 model is used with a threaded rod size of 1/4 inch or 3/8 inch; the KCM-MD SP-1/4-3/8-1/2 model is used with a threaded rod size of 1/4 inch, 3/8 inch or 1/2 inch, the KCM-MD SP 3/8-1/2 model is used with a threaded rod size of 3/8 inch or 1/2 inch; the KCM-MD SP 3/8-1/2-5/8 model is

used with a threaded rod size of $\frac{3}{8}$ inch, $\frac{1}{2}$ inch, or $\frac{5}{8}$ inch; the KCM-MD SP 5/8-3/4 model is used with a threaded rod size of $\frac{5}{8}$ inch or $\frac{3}{4}$ inch.

There are 5 models for Hilti KCM-MD LP. The KCM-MD LP 1/4-3/8 model is used with a threaded rod size of $\frac{1}{4}$ inch or $\frac{3}{8}$ inch; the KCM-MD SP-1/4-3/8-1/2 model is used with a threaded rod size of $\frac{1}{4}$ inch, $\frac{3}{8}$ inch or $\frac{1}{2}$ inch, the KCM-MD LP 3/8-1/2 model is used with a threaded rod size of $\frac{3}{8}$ inch or $\frac{1}{2}$ inch; the KCM-MD LP 3/8-1/2-5/8 model is used with a threaded rod size of $\frac{3}{8}$ inch, $\frac{1}{2}$ inch, or $\frac{5}{8}$ inch; the KCM-MD LP 5/8-3/4 model is used with a threaded rod size of $\frac{5}{8}$ inch or $\frac{3}{4}$ inch.

Reference to “inserts” in this report refers to the proprietary specialty anchorage products (KCC-WF, KCCM-WF, KCM-WF, KCM-PD, KCC-MD SP, KCC-MD LP, KCCM-MD SP, KCCM-MD LP, KCM-MD SP, and KCM-MD LP) used in concrete; reference to “steel insert elements” refers to threaded rods or bolts; reference to “anchors” or “insert anchor system” in this report refers to the installed inserts in concrete with threaded rods or bolts.

The insert anchor system is an alternative to cast-in anchors described in Section 1901.3 of the 2024, 2021, 2018 and 2015 IBC. The insert anchor system may be used where an engineered design is submitted in accordance with Section R301.1.3 of the IRC.

3.0 DESCRIPTION

3.1 KCC-WF, KCC-MD SP, KCC-MD LP, KCCM-WF, KCCM-MD SP, KCCM-MD LP, KCM-WF, KCM-PD, KCM-MD SP, and KCM-MD LP:

Hilti KCC-WF, KCC-MD SP, KCC-MD LP, KCCM-WF, KCCM-MD SP, KCCM-MD LP, KCM-WF, KCM-PD, KCM-MD SP, and KCM-MD LP are steel internally threaded headed cast-in specialty inserts which receive threaded steel insert elements such as threaded rods and bolts in $\frac{1}{4}$ -inch, $\frac{3}{8}$ -inch, $\frac{1}{2}$ -inch, $\frac{5}{8}$ -inch, $\frac{3}{4}$ -inch, M10 and M12 thread diameters.

The KCC-WF, KCC-MD SP, KCC-MD LP, KCCM-WF, KCCM-MD SP, and KCCM-MD LP do not require rotation of the threaded rod for installation. The threaded rod is pushed into the insert.

Inserts are manufactured from carbon steel and have a minimum 5.0 μm (0.0002 inch) zinc coating. The steel outer shell is covered in a thin plastic housing up to the steel head bearing surface. The KCC-WF, KCCM-WF, and KCM-WF are illustrated in Figure 1; the KCM-PD is illustrated in Figure 2; the KCC-MD SP, KCCM-MD SP and KCM-MD SP are illustrated in Figure 3; KCC-MD LP, KCCM-MD LP and KCM-MD LP are illustrated in Figure 4.

The KCC-WF, KCCM-WF, and KCM-WF inserts are installed into the wood-form for a concrete member using the attached nails prior to the casting of the concrete. The inserted threaded rod or bolt can be installed into the internally threaded section of the KCC-WF, KCCM-WF or KCM-WF after the wood-form is removed from the concrete.

The KCM-PD insert is installed into the removable pan joist deck for a concrete member using self-drilling screws prior to the casting of the concrete. The inserted threaded rod or bolt can be installed into the internally threaded section of the KCM-PD after the pan joist deck is removed from the concrete.

The KCC-MD, KCCM-MD and KCM-MD inserts are installed into a hole cut into metal deck panels from the top-side that will be filled with a concrete topping slab. The inserted threaded rod or bolt can be installed from the underside of the metal deck panel in the internally threaded section of the KCC-MD, KCCM-MD or KCM-MD

The inserts are color coded as indicated in Tables 1, 2A and 2B. Figures 1, 2, 3, 4, 5A, 5B, 5C, and 5D show diagrams of the installed KCC-WF, KCCM-WF, KCM-WF, KCM-PD, KCC-MD, KCCM-MD and KCM-MD in a concrete member.

3.2 Steel Insert Elements:

3.2.1 Threaded Steel Rods and Bolts: Threaded steel rods (all-thread) or bolts must be threaded into the KCC-WF, KCCM-WF, KCM-WF, KCM-PD, KCC-MD, KCCM-MD or KCM-MD. Carbon steel threaded rods or bolts must be furnished with a minimum 5.1 μm (0.0002 inch) zinc plating. Steel design information for common grades of threaded rods is provided in Tables 5 and 6.

3.2.2 Ductility: In accordance with ACI 318 (-19 and -14) 2.3, as applicable, in order for a steel anchor element to be considered ductile, the tested elongation must be at least 14 percent and the reduction of area must be at least 30 percent. Steel elements with a tested elongation of less than 14 percent or a reduction of area less than 30 percent, or both, are considered brittle. The Hilti KCC-WF, KCCM-WF, KCM-WF, KCM-PD, KCC-MD, KCCM-MD and KCM-MD Headed Cast-In Specialty Insert steel bodies are considered brittle elements. Where values are nonconforming or unstated, the steel element must be considered brittle.

3.3 Concrete:

Normal-weight and lightweight concrete must conform to Sections 1903 and 1905 of the IBC.

3.4 Metal Deck Panels:

Metal deck panels must be in accordance with the configuration shown in Figures 5A, 5B, 5C, and 5D and have a minimum base steel thickness of 0.035 inch (0.899 mm). Steel must comply with ASTM A653/A653M SS Grade 50 minimum and have a minimum yield strength of 50,000 psi (345 MPa).

4.0 DESIGN AND INSTALLATION

4.1 Strength Design:

4.1.1 General: Design strength of anchors complying with the 2024 and 2021 IBC as well as Section R301.1.3 of the 2024 and 2021 IRC, must be determined in accordance with ACI 318-19 Chapter 17 and this report.

Design strength of anchors complying with the 2018 and 2015 IBC as well as Section R301.1.3 of the 2018 and 2015 IRC, must be determined in accordance with ACI 318-14 Chapter 17 and this report.

Design parameters provided in this report are based on the 2024 and 2021 IBC (ACI 318-19), 2018 and 2015 IBC (ACI 318-14) unless noted otherwise in Sections 4.1.1 through 4.1.13. The strength design of anchors must comply with ACI 318-19 17.5.1.2 or ACI 318-14 17.3.1, except as required in ACI 318-19 17.10 or ACI 318-14 17.2.3, as applicable.

Strength reduction factors, ϕ , as given in ACI 318-19 17.5.3 or ACI 318-14 17.3.3, as applicable, for cast-in headed anchors, must be used for load combinations calculated in accordance with Section 1605.1 of the 2024 and 2021 IBC or Section 1605.2 of the 2018 and 2015 IBC, Section 5.3 of ACI 318-19 or ACI 318-14, as applicable. The value of f'_c used in the calculations must be limited to a maximum of 10,000 psi (68.9 MPa), in accordance with ACI 318-19 17.3.1, ACI 318-14 17.2.7, as applicable.

4.1.2 Requirements for Static Steel Strength in Tension: The nominal static steel strength in tension, N_{sa} ,

of a single anchor must be calculated in accordance with ACI 318-19 17.6.1 or ACI 318-14 17.4.1, as applicable, for the threaded steel insert element (threaded rod), not to exceed the values of $N_{sa,insert}$ in Tables 3A, 3B, 4A and 4B of this report. Strength reduction factor, ϕ , corresponding to non-ductile steel shall be used when, $\phi N_{sa,insert}$, controls the design strength. When the threaded rod strength controls, the strength reduction factor, ϕ , corresponding to the threaded rod shall be used.

4.1.3 Requirements for Static Concrete Breakout Strength in Tension: For wood form (KCC-WF, KCCM-WF and KCM-WF) or pan joist deck (KCM-PD) inserts, the nominal concrete breakout strength of a single anchor or group of anchors in tension, N_{cb} or N_{cbg} , respectively, must be calculated in accordance with ACI 318-19 17.6.2 or ACI 318-14 17.4.2, as applicable, for cast-in headed bolts. The basic concrete breakout strength in tension, N_b , must be calculated in accordance with ACI 318-19 17.6.2.2 or ACI 318-14 17.4.2.2, as applicable, using the values of h_{ef} given in Table 1, and with $k_c = 24$. The nominal concrete breakout strength in tension in regions where analysis indicates no cracking in accordance with ACI 318-19 17.6.2.5 or ACI 318-14 17.4.2.6, as applicable, must be calculated with $\psi_{c,N} = 1.25$.

For the metal deck inserts (KCC-MD, KCCM-MD and KCM-MD) installed in the soffit of sand-lightweight or normal-weight concrete over metal deck floor and roof assemblies as shown in Figures 5A, 5B, 5C and 5D, calculation of the concrete breakout strength is not required.

4.1.4 Static Pullout Strength in Tension: The pullout strength in tension for the KCC-WF, KCCM-WF, KCM-WF and KCM-PD inserts does not control design, and need not be calculated.

For the KCC-MD, KCCM-MD and KCM-MD installed in the soffit of sand-lightweight or normal-weight concrete over metal deck, the nominal pullout strength of a single anchor in cracked and uncracked concrete, $N_{pn,deck,cr}$ and $N_{pn,deck,un-cr}$, respectively, is given in Tables 4A, 4B and 4C of this report. In accordance with ACI 318-19 17.6.3 or ACI 318-14 17.4.3, as applicable, the nominal pullout strength in cracked concrete may be calculated in accordance with the following equation:

$$N_{p,f'_c} = N_{pn,deck,cr} \sqrt{\frac{f'_c}{3,000}} \quad (\text{lb, psi}) \quad (\text{Eq-1})$$

$$N_{p,f'_c} = N_{pn,deck,cr} \sqrt{\frac{f'_c}{20.7}} \quad (\text{N, MPa})$$

In regions where analysis indicates no cracking in accordance with ACI 318-19 17.6.3.3 or ACI 318-14 17.4.3.6, as applicable, the nominal pullout strength in tension may be calculated in accordance with the following equation:

$$N_{p,f'_c} = N_{pn,deck,un-cr} \sqrt{\frac{f'_c}{3,000}} \quad (\text{lb, psi}) \quad (\text{Eq-2})$$

$$N_{p,f'_c} = N_{pn,deck,un-cr} \sqrt{\frac{f'_c}{20.7}} \quad (\text{N, MPa})$$

4.1.5 Requirements for Static Side-Face Blowout Strength in Tension: For the KCC-WF, KCCM-WF, KCM-WF, and KCM-PD, the nominal side-face blowout strength of a headed insert, N_{sb} , must be calculated in accordance with ACI 318-19 17.6.4.1 or ACI 318-14 17.4.4.1, as applicable, for the cast-in headed insert, using the values of A_{brg} as given in Table 1 of this report, as applicable.

For the KCC-MD, KCCM-MD and KCM-MD inserts installed in the soffit of sand-lightweight or normal-weight

concrete over metal deck floor and roof assemblies as shown in Figures 5A, 5B, 5C and 5D, calculation of the concrete side-face blowout strength is not required.

4.1.6 Requirements for Static Steel Strength in Shear: For wood form (KCC-WF, KCCM-WF and KCM-WF) or pan joist deck (KCM-PD) inserts, the nominal static steel strength of a single anchor in shear, V_{sa} , of a single insert is given in Tables 3A and 3B and must be used in lieu of the values derived by calculation from ACI 318-19 Eq. 17.7.1.2b or ACI 318-14 Eq. 17.5.1.2b, as applicable.

For metal deck (KCC-MD, KCCM-MD and KCM-MD) inserts, the nominal steel strength in shear, $V_{sa,deck}$, of a single insert, are given in Tables 4A, 4B and 4C of this report and must be used in lieu of the values derived by calculation from ACI 318-19 Eq. 17.7.1.2b or ACI 318-14 Eq. 17.5.1.2b, as applicable.

The values given in Tables 3A, 3B, 4A, 4B and 4C are for the insert only. Determination of the shear capacity of the threaded rod or other material inserted into the cast-in insert is the responsibility of the design professional.

4.1.7 Requirements for Static Concrete Breakout Strength in Shear: For the KCC-WF, KCCM-WF, KCM-WF and KCM-PD, the nominal static concrete breakout strength of a single anchor or group of anchors in shear, V_{cb} or V_{cbg} , respectively, must be calculated in accordance with ACI 318-19 17.7.2 or ACI 318-14 17.5.2, as applicable. The basic concrete breakout strength, V_b , must be calculated in accordance with ACI 318-19 17.7.2.2 or ACI 318-14 17.5.2.2 based on the values provided in Table 1. The values of $l_e (=h_{ef})$ and d_a used in ACI 318-19 Eq. 17.7.2.2.1a or ACI 318-14 Eq. 17.5.2.2a, as applicable, are provided in Table 1 of this report.

For metal deck (KCC-MD, KCCM-MD and KCM-MD) inserts installed in the soffit of sand-lightweight or normal-weight concrete on steel deck floor and roof assemblies, as shown in Figures 5A, 5B, 5C and 5D, calculation of the concrete breakout strength in shear is not required.

4.1.8 Requirements for Static Concrete Pryout Strength in Shear: For KCC-WF, KCCM-WF, KCM-WF and KCM-PD inserts, the nominal concrete pryout strength of a single anchor or group of anchors, V_{cp} or V_{cpg} , respectively, must be calculated in accordance with ACI 318-19 17.7.3 or ACI 318-14 17.5.3, as applicable.

For metal deck inserts (KCC-MD, KCCM-MD and KCM-MD) installed in the soffit of sand-lightweight or normal-weight concrete over metal deck floor and roof assemblies, as shown in Figures 5A, 5B, 5C and 5D, calculation of the concrete pry-out strength in shear is not required.

4.1.9 Requirements for Seismic Design:

4.1.9.1 General: For load combinations including seismic, the design must be performed in accordance with ACI 318-19 17.10 or ACI 318-14 17.2.3, as applicable. Modifications to ACI 318-19 17.10, ACI 318-14 17.2.3 shall be applied under Section 1905.7 of the 2024 IBC or Section 1905.1.8 of the 2021, 2018 and 2015 IBC, as applicable. The anchors may be installed in Seismic Design Categories A through F of the IBC. The inserts comply with ACI 318 (-19, -14) 2.3, as applicable, as non-ductile steel elements.

For the KCC-WF, KCCM-WF, KCM-WF and KCM-PD inserts, the nominal steel strength, nominal concrete breakout strength and nominal concrete side-face blowout strength for anchors in tension; and the nominal concrete breakout strength and pryout strength in shear, must be calculated in accordance with ACI 318-19 17.6 and 17.7 or

ACI 318-14 17.4 and 17.5, as applicable, using the values in Tables 1 through 4, as applicable.

For the KCC-MD, KCCM-MD and KCM-MD inserts, the nominal steel strength and nominal concrete pullout strength for anchors in tension must be calculated using the values in Tables 2A and 2B and Tables 4A and 4B, as applicable.

4.1.9.2 Seismic Tension: For KCC-WF, KCCM-WF, KCM-WF and KCM-PD inserts, the nominal steel strength in tension, $N_{sa,eq}$, of a single anchor must be calculated in accordance with ACI 318-19 17.6.1 or ACI 318-14 17.4.1, as applicable, for the threaded steel element, not to exceed the corresponding values of $N_{sa,insert,eq}$ in Tables 3A and 3B of this report; the nominal concrete breakout strength for anchors in tension must be calculated in accordance with ACI 318-19 17.6.2 or ACI 318-14 17.4.2, as applicable, as described in Section 4.1.3 of this report; the nominal pullout strength in accordance with ACI 318-19 17.6.3 or ACI 318-14 17.4.3, as applicable, need not be considered as noted in Section 4.1.4 of this report; the nominal concrete side-face blowout strength must be calculated in accordance with ACI 318-19 17.6.4.1 and 17.6.4.2 or ACI 318-14 17.4.4.1 and 17.4.4.2, as applicable, and Section 4.1.5 of this report.

For KCC-MD, KCCM-MD and KCM-MD metal deck inserts, the nominal steel strength in tension, $N_{sa,eq}$, of a single anchor must be calculated in accordance with ACI 318-19 17.6.1 or ACI 318-14 17.4.1, as applicable, for the threaded rod, not to exceed the nominal steel strength, $N_{sa,insert,eq}$, provided in Tables 4A, 4B and 4C; the nominal concrete pullout strength is given in Tables 4A and 4B and 4C, and must be used in lieu of calculations in accordance with ACI 318-19 17.6.3 or ACI 318-14 17.4.3, as applicable; the nominal concrete breakout strength calculations in accordance with ACI 318-19 17.6.2 or ACI 318-14 17.4.2, are not required, as noted in Section 4.1.3 of this report.

4.1.9.3 Seismic Shear: For KCC-WF, KCCM-WF, KCM-WF and KCM-PD inserts, the nominal concrete breakout strength and pryout strength in shear must be calculated in accordance with ACI 318-19 17.7.2 and 17.7.3 or ACI 318-14 17.5.2 and 17.5.3, as applicable, as described in Sections 4.1.7 and 4.1.8 of this report. In accordance with ACI 318-19 17.7.1.2 or ACI 318-14 17.5.1.2, as applicable, the nominal steel strength for seismic loads, $V_{sa,eq}$, must be taken as the threaded steel element strength, not to exceed the corresponding values of $V_{sa,insert,eq}$ in Tables 3A and 3B.

For KCC-MD, KCCM-MD and KCM-MD metal deck inserts, the nominal concrete breakout strength and pryout strength in shear, in accordance with ACI 318-19 17.7.2 and 17.7.3 or ACI 318-14 17.5.2 and 17.5.3, are not required, as described in Sections 4.1.7 and 4.1.8 of this report. In accordance with ACI 318-19 17.7.1.2 or ACI 318-14 17.5.1.2, as applicable, the appropriate value for nominal steel strength for seismic loads, $V_{sa,eq}$, must be taken as the threaded steel element strength, not to exceed the corresponding values of $V_{sa,deck,eq}$ described in Tables 4A, 4B and 4C.

4.1.10 Requirements for Interaction of Tensile and Shear Forces: For designs that include combined tension and shear, the interaction of tension and shear loads must be calculated in accordance with ACI 318-19 17.8 or ACI 318-14 17.6, as applicable.

4.1.11 Requirements for Minimum Member Thickness, h_{min} , Minimum Anchor Spacing, s_{min} , and Minimum Edge Distance, c_{min} : Requirements on headed cast-in specialty anchor edge distance, spacing, member thickness, and concrete strength must be in accordance

with the requirements in ACI 318-19 or ACI 318-14, as applicable, for cast-in bolts.

For KCC-MD, KCCM-MD and KCM-MD metal deck inserts installed in the soffit of sand-lightweight or normal-weight concrete on metal deck floor and roof assemblies, the anchors must be installed in accordance with Figures 5A, 5B, 5C and 5D and shall have a minimum axial spacing along the flute equal to $3h_{ef}$.

4.1.12 Requirements for Critical Edge Distance: The calculation of the critical edge distance, c_{ac} , is not required, since the modification factor $\Psi_{cp,N} = 1.0$ for cast-in anchors in accordance with ACI 318-19 17.6.2.6 or ACI 318-14 17.4.2.7, as applicable.

4.1.13 Lightweight Concrete: For the KCC-WF, KCCM-WF, KCM-WF and KCM-PD in lightweight concrete, the modification factor λ , for concrete breakout strength must be in accordance with ACI 318-19 17.2.4 (2021 IBC) or ACI 318-14 17.2.6 (2018 and 2015 IBC).

For KCC-MD, KCCM-MD and KCM-MD metal deck inserts in the soffit of sand-lightweight concrete-filled metal deck, this reduction is not required. Values shown in Tables 4A, 4B and 4C are based on use in sand-lightweight concrete and are also valid for normal weight concrete. Installation details are shown in Figures 5A, 5B, 5C and 5D.

4.2 Allowable Stress Design (ASD):

4.2.1 General: Design values for use with allowable stress design (working stress design) load combinations calculated in accordance with Section 1605.3 of the IBC, must be established as follows:

$$T_{allowable,ASD} = \frac{\phi N_n}{\alpha}$$

$$V_{allowable,ASD} = \frac{\phi V_n}{\alpha}$$

where:

$T_{allowable,ASD}$ = Allowable tension load (lbf or kN).

$V_{allowable,ASD}$ = Allowable shear load (lbf or kN).

ϕN_n = Lowest design strength of an anchor or anchor group in tension as determined in accordance with ACI 318-19 17.5.1.2, ACI 318-14 17.3.1, 2024 IBC Section 1905.7 and 2018 and 2015 IBC Section 1905.1.8 (lbf or N).

ϕV_n = Lowest design strength of an anchor or anchor group in shear as determined in accordance with ACI 318-19 17.5.1.2, ACI 318-14 17.3.1, 2024 IBC Section 1905.7 and 2018 and 2015 IBC Section 1905.1.8 (lbf or N).

α = Conversion factor calculated as a weighted average of the load factors for the controlling load combination. In addition, α must include all applicable factors to account for non-ductile failure modes and required over-strength.

The requirements for member thickness, edge distance and spacing, described in this report, must apply.

4.2.2 Interaction of Tensile and Shear Forces: For designs that include combined tension and shear, the interaction of tension and shear loads must be calculated in accordance with ACI 318-19 17.8 or ACI 318-14 17.6, as applicable, as follows:

For shear loads $V_{applied} \leq 0.2V_{allowable,ASD}$, the full allowable load in tension must be permitted.

For tension loads $T_{applied} \leq 0.2T_{allowable,ASD}$, the full allowable load in shear must be permitted.

For all other cases:

$$\frac{T_{applied}}{T_{allowable,ASD}} + \frac{V_{applied}}{V_{allowable,ASD}} \leq 1.2 \quad (\text{Eq-3})$$

4.3 Installation:

For the KCC-WF, KCCM-WF, KCM-WF, KCM-PD, KCC-MD, KCCM-MD and KCM-MD inserts, installation parameters are provided in Tables 1, 2A and 2B. Installation must be in accordance with this evaluation report and the manufacturer's printed installation instruction (MPII) as provided in Figures 6 through 12 of this report. In the event of a conflict between this report and the MPII, this report governs. The KCC insert product line allows the installer to insert the threaded rod by pushing it into the insert without turning.

4.4 Special Inspection:

Periodic special inspection is required in accordance with Section 1705.1.1 and Table 1705.3 of the 2024, 2021, 2018 or 2015 IBC, as applicable. The special inspector must make periodic inspections during installation of the headed cast-in specialty inserts to verify insert type, insert dimensions, concrete type, concrete compressive strength, insert spacing, edge distances, concrete member thickness, insert embedment, threaded rod fully seated into insert, and adherence to the manufacturer's printed installation instructions. The special inspector must be present as often as required in accordance with the "statement of special inspection." Under the IBC, additional requirements as set forth in Sections 1705, 1706 and 1707 must be observed, where applicable.

5.0 CONDITIONS OF USE

The KCC-WF, KCCM-WF, KCM-WF, KCM-PD, KCC-MD, KCCM-MD and KCM-MD concrete inserts described in this report are acceptable alternatives to what is specified in the codes listed in Section 1.0 of this report, subject to the following conditions:

- 5.1 Specialty inserts are limited to dry interior locations.
- 5.2 Specialty insert sizes, dimensions, minimum embedment depths, and other installation parameters are as set forth in this report.
- 5.3 Specialty inserts must be installed in accordance with the manufacturer's printed installation instructions (MPII) and this report. In case of conflict, this report governs.
- 5.4 Specialty inserts must be limited to use in cracked and uncracked normal-weight concrete, and lightweight concrete having a specified compressive strength, f_c , of 2,500 psi to 10,000 psi (17.2 MPa to 68.9 MPa) for the KCC-WF, KCCM-WF, KCM-WF and KCM-PD inserts, and cracked and uncracked normal-weight or sand-lightweight concrete over steel deck having a minimum specified compressive strength, f_c , of 3000 psi (20.7MPa) for the KCC-MD, KCCM-MD and KCM-MD inserts.
- 5.5 The values of f_c used for calculation purposes must not exceed 10,000 psi (68.9 MPa).
- 5.6 The concrete shall have achieved its minimum design strength prior to loading of the specialty inserts.
- 5.7 Strength design values must be established in accordance with Section 4.1 of this report.

5.8 Allowable design values are established in accordance with Section 4.2.

5.9 Specialty insert spacing and edge distance as well as minimum member thickness must comply with ACI 318-19 17.9 or ACI 318-14 17.7 requirements, as applicable, for cast-in-place headed anchors, and Tables 1, 2A and 2B of this report.

5.10 Prior to installation, calculations and details demonstrating compliance with this report must be submitted to the code official. The calculations and details must be prepared by a registered design professional where required by the statutes of the jurisdiction in which the project is to be constructed.

5.11 Since an ICC-ES acceptance criteria for evaluating data to determine the performance of the specialty inserts subjected to fatigue or shock loading is unavailable at this time, the use of these inserts under such conditions is beyond the scope of this report.

5.12 Specialty inserts may be installed in regions of concrete where analysis indicates cracking may occur ($f_t > f_r$), subject to the conditions of this report.

5.13 Specialty inserts may be used to resist short-term loading due to wind or seismic forces in locations designated as Seismic Design Categories A through F of the IBC, subject to the conditions of this report.

5.14 Where not otherwise prohibited in the code, inserts are permitted for use with fire-resistance-rated construction provided that at least one of the following conditions is fulfilled:

- Headed cast-in specialty inserts that support a fire-resistance-rated envelope or a fire-resistance-rated membrane are protected by approved fire-resistance-rated materials, or have been evaluated for resistance to fire exposure in accordance with recognized standards.
- Headed cast-in specialty inserts are used to resist wind or seismic forces only.
- Headed cast-in specialty inserts are used to support nonstructural elements.

5.15 Special inspection must be provided in accordance with Section 4.4.

5.16 Specialty inserts are manufactured under an approved quality control program with inspections by ICC-ES.

6.0 EVIDENCE SUBMITTED

6.1 Data in accordance with the ICC-ES Acceptance Criteria for Headed Cast-in Specialty Inserts in Concrete (AC446), dated August 2018 (Editorially revised May 2021).

6.2 Quality-control documentation.

7.0 IDENTIFICATION

7.1 The ICC-ES mark of conformity, electronic labeling, or the evaluation report number (ICC-ES ESR-4145) along with the name, registered trademark, or registered logo of the report holder or listee must be included in the product label.

7.2 In addition, The KCC-WF, KCCM-WF, KCM-WF, KCM-PD, KCC-MD, KCCM-MD and KCM-MD inserts are identified by packaging labeled with the company name (Hilti, Inc.) and contact information, insert name, insert size and lot number. The inserts have various colored plastic housings to identify the product size.

7.3 The report holder's contact information is the following:

HILTI, INC.
7250 DALLAS PARKWAY, SUITE 1000
PLANO, TEXAS 75024
(800) 879-8000
www.hilti.com

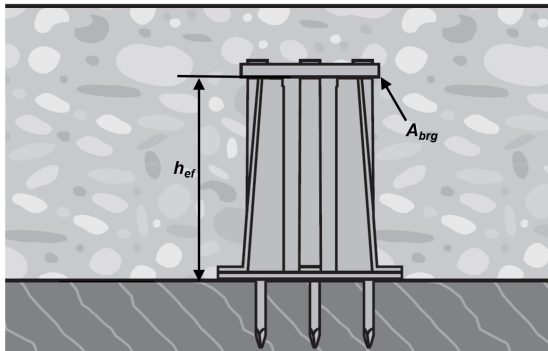

FIGURE 1—HILTI KCC-WF, KCCM-WF, AND KCM-WF ANCHORS INSTALLED IN CONCRETE

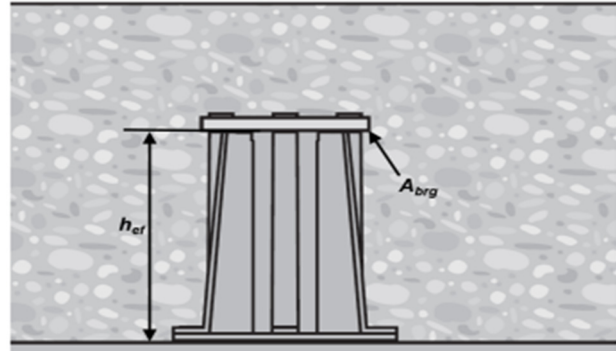

FIGURE 2—HILTI KCM-PD ANCHOR INSTALLED IN CONCRETE

TABLE 1A—HILTI KCM-WF AND KCM-PD CAST-IN INSERT INSTALLATION INFORMATION

DESIGN INFORMATION	SYMBOL	UNITS	KCM-WF and KCM-PD 1/4"-3/8"	KCM-WF 1/4"-3/8"-1/2"	KCM-WF 3/8"-1/2", M10-M12	KCM-WF and KCM-PD 3/8"-1/2"-5/8"	KCM-WF and KCM-PD 3/8"-1/2"-5/8"-3/4"	KCM-WF 5/8"-3/4"
Effective embedment ¹	h_{ef}	in. (mm)	1.12 (28)	1.63 (41)	1.63 (41)	2.04 (52)	3.0 (76)	2.5 (64)
Min. member thickness	h_{min}	in. (mm)	2 1/2 (64)	2 1/2 (64)	2 1/2 (64)	3 (76)	4 (102)	3 1/2 (90)
Outside anchor diameter	d_a	in. (mm)	0.51 (13)	0.67 (17)	0.67 (17)	0.87 (22.1)	1.02 (25.9)	1.00 (25.4)
Bearing area	A_{brg}	in. ² (mm ²)	0.91 (590)	0.96 (619)	0.96 (619)	1.23 (792)	2.25 (1,451)	1.33 (858)
Minimum anchor spacing ²	s_{min}	in. (mm)	2.0 (51)	2.6 (67)	2.6 (67)	3.5 (88)	4.1 (104)	4.0 (102)

For **SI**: 1 inch = 25.4 mm. For **pound-inch units**: 1 mm = 0.03937 inches.

¹ See figures 1 and 2.

² Minimum spacing distances are based on $4d_a$ for anchors that will not be torqued in accordance with ACI 318-19 17.9.2 or ACI 318-14 17.7.1, as applicable.

TABLE 1B—HILTI KCC-WF AND KCCM-WF CAST-IN INSERT INSTALLATION INFORMATION

DESIGN INFORMATION	SYMBOL	UNITS	KCC-WF 3/8"	KCC-WF 1/2"	KCCM-WF 1/4"-3/8"	KCCM-WF 3/8"-1/2"
Effective embedment ¹	h_{ef}	in. (mm)	1.63 (41)	2.04 (52)	2.04 (52)	2.25 (57)
Min. member thickness	h_{min}	in. (mm)	2 1/2 (64)	3 (76)	2 3/4 (70)	3 (76)
Outside anchor diameter	d_a	in. (mm)	0.67 (17.0)	0.87 (22.1)	0.89 (22.6)	1.05 (26.6)
Bearing area	A_{brg}	in. ² (mm ²)	1.00 (643)	1.23 (792)	0.95 (611)	1.30 (841)
Minimum anchor spacing ²	s_{min}	in. (mm)	2 5/8 (68)	3 1/2 (88)	3 1/2 (90)	4 1/4 (106)

For **SI**: 1 inch = 25.4 mm. For **pound-inch units**: 1 mm = 0.03937 inches.

¹ See figures 1 and 2.

² Minimum spacing distances are based on $4d_a$ for anchors that will not be torqued in accordance with ACI 318-19 17.9.2 or ACI 318-14 17.7.1, as applicable.

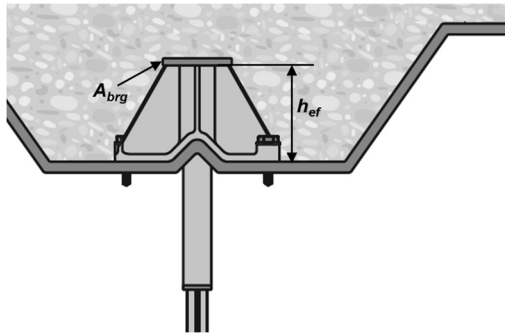

FIGURE 3— HILTI KCC-MD SP, KCCM-MD SP AND KCM-MD SP ANCHORS INSTALLED IN SOFFIT OF CONCRETE FILLED METAL DECK FLOOR AND ROOF ASSEMBLIES

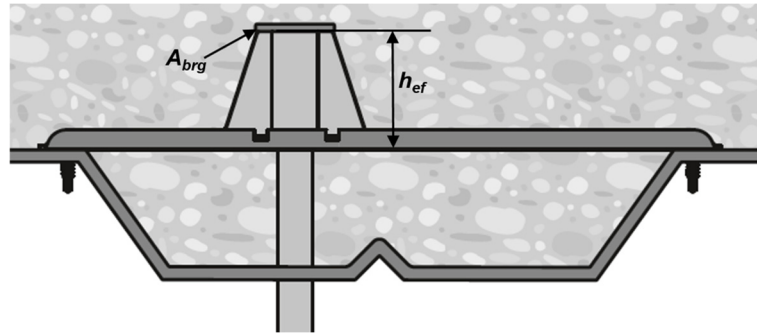

FIGURE 4— HILTI KCC-MD LP, KCCM-MD LP AND KCM-MD LP ANCHORS INSTALLED IN SOFFIT OF CONCRETE FILLED METAL DECK FLOOR AND ROOF ASSEMBLIES

TABLE 2A—HILTI KCM-MD SP AND KCM-MD LP CAST-IN INSERT INSTALLATION INFORMATION

DESIGN INFORMATION	SYMBOL	UNITS	KCM-MD SP AND KCM-MD LP 1/4"-3/8"	KCM-MD SP AND KCM-MD LP 1/4"-3/8"-1/2"	KCM-MD SP AND KCM-MD LP 3/8"-1/2"	KCM-MD SP AND KCM-MD LP 3/8"-1/2"-5/8"	KCM-MD SP AND KCM-MD LP 5/8"-3/4"
Effective embedment ¹	h_{ef}	in. (mm)	1.76 (45)	2.00 (51)	2.00 (51)	2.50 (64)	2.50 (64)
Metal hole saw diameter	$d_{bit}(SP)$	in.	9/16	11/16	11/16	13/16	15/16
	$d_{bit}(LP)$		1/2	5/8	5/8	3/4	7/8
Min. concrete cover over metal deck - upper flute install ²	$h_{upper,min}$	in. (mm)	2 1/2 (64)	2 1/2 (64)	2 1/2 (64)	3 1/4 (83)	3 1/4 (83)
Min. concrete cover over metal deck lower flute install ³	$h_{lower,min}$	in. (mm)	2 1/2 (64)	2 1/2 (64)	2 1/2 (64)	3 1/4 (83)	3 1/4 (83)
Min. metal deck gauge	-	-	20				
Outside anchor diameter	d_a	in. (mm)	0.51 (13)	0.67 (17)	0.67 (17)	0.87 (22.1)	1.00 (25)
Bearing area	A_{brg}	in. ² (mm ²)	0.90 (577)	1.00 (627)	1.00 (627)	1.20 (771)	1.30 (842)
Min. anchor spacing	s_{min}	in. (mm)	5 1/4 (134)	6 (152)	6 (152)	7 1/2 (191)	7 1/2 (191)

For SI: 1 inch = 25.4 mm. For pound-inch unit: 1 mm = 0.03937 inches.

¹ See Figures 3 and 4.

² See Figures 5A and 5D

³ See Figures 5B and 5C.

TABLE 2B—HILTI KCC-MD SP, KCC-MD LP, KCCM-MD SP AND KCCM-MD LP CAST-IN INSERT INSTALLATION INFORMATION

DESIGN INFORMATION	SYMBOL	UNITS	KCC-MD SP AND KCC-MD LP 3/8"	KCC-MD SP AND KCC-MD LP 1/2"	KCCM-MD SP AND KCCM-MD LP 1/4"-3/8"	KCCM-MD SP AND KCCM-MD LP 3/8"-1/2"
Effective embedment ¹	h_{ef}	in. (mm)	2.00 (51)	2.50 (64)	2.32 (59)	2.60 (66)
Metal hole saw diameter	$d_{bit}(SP)$	in.	11/16	13/16	13/16	15/16
	$d_{bit}(LP)$		5/8	3/4	3/4	7/8
Min. concrete cover over metal deck - upper flute install ²	$h_{upper,min}$	in. (mm)	2 1/2 (64)	3 1/4 (83)	3 (76)	3 1/4 (83)
Min. concrete cover over metal deck lower flute install ³	$h_{lower,min}$	in. (mm)	2 1/2 (64)	3 1/4 (83)	2 1/2 (64)	3 1/4 (83)
Min. metal deck gauge	-	-	20			
Outside anchor diameter	d_a	in. (mm)	0.67 (17)	0.87 (22.1)	0.87 (22)	1.00 (25.4)
Bearing area	A_{brg}	in. ² (mm ²)	1.00 (627)	1.20 (771)	0.95 (611)	1.30 (841)
Min. anchor spacing	s_{min}	in. (mm)	6 (152)	7 1/2 (191)	7 (177)	7 3/4 (198)

For SI: 1 inch = 25.4 mm, 1 pound = 0.00445 kN, 1 in² = 645.2 mm². For pound-inch unit: 1 mm = 0.03937 inches.

¹ See Figures 3 and 4.

² See Figures 5A and 5D

³ See Figures 5B and 5C.

TABLE 3A—HILTI KCM-WF AND KCM-PD CAST-IN INSERT DESIGN INFORMATION^{1,7}

DESIGN INFORMATION	SYMBOL	UNITS	KCM-WF and KCM-PD ^{1/4"} - ^{3/8"}		KCM-WF ^{1/4"} - ^{3/8"} - ^{1/2"}			KCM-WF ^{3/8"} - ^{1/2"} M10-M12		KCM-WF and KCM-PD ^{3/8"} - ^{1/2"} - ^{5/8"}			KCM-WF and KCM-PD ^{3/8"} - ^{1/2"} - ^{5/8"} - ^{3/4"}				KCM-WF ^{5/8"} - ^{3/4"}	
			^{1/4"}	^{3/8"}	^{1/4"}	^{3/8"}	^{1/2"}	^{3/8"} M10 ⁶	^{1/2"} M12	^{3/8"}	^{1/2"}	^{5/8"}	^{3/8"}	^{1/2"} (6)	^{5/8"} (6)	^{3/4"}	^{5/8"}	^{3/4"}
Effective Embedment	h_{ef}	in. (mm)	1.12 (28)		1.63 (41)			1.63 (41)		2.04 (52)			3.0 (76)				2.5 (64)	
Outside anchor diameter	d_b	in. (mm)	0.51 (13)		0.67 (17)			0.67 (17)		0.87 (22.1)			1.02 (25.9)				1.00 (25.4)	
Nominal rod diameter	-	in. or mm	^{1/4"}	^{3/8"}	^{1/4"}	^{3/8"}	^{1/2"}	^{3/8"} M10 ⁶	^{1/2"} M12	^{3/8"}	^{1/2"}	^{5/8"}	^{3/8"}	^{1/2"} (6)	^{5/8"} (6)	^{3/4"}	^{5/8"}	^{3/4"}
Nominal steel strength in tension as governed by the insert ²	$N_{sa,insert}$	lb (kN)	8,175 (36.4)		12,365 (55)			12,365 (55)		16,800 (74.7)			27,380 (121.8)				22,500 (100.1)	
Nominal seismic steel strength in tension as governed by the insert ²	$N_{sa,insert,eq}$	lb (kN)	N/A	8,175 (36.4)	N/A	12,365 (55)	12,365 (55)	12,365 (55)	12,365 (55)	N/A	16,800 (74.7)	16,800 (74.7)	N/A	27,380 (121.8)	27,380 (121.8)	27,380 (121.8)	22,500 (100.1)	22,500 (100.1)
Nominal steel strength in shear as governed by the insert ²	$V_{sa,insert}$	lb (kN)	N/A	2,955 (13.1)	N/A	3,470 (15.4)	5,820 (25.9)	3,335 (14.8)	5,820 (25.9)	N/A	6,085 (27.1)	9,640 (42.9)	N/A	8,260 (36.7)	13,745 (61.1)	18,570 (82.6)	10,385 (46.2)	11,055 (49.2)
Nominal seismic steel strength in shear as governed by the insert ²	$V_{sa,insert,eq}$	lb (kN)	N/A	2,955 (13.1)	N/A	2,085 (9.3)	5,820 (25.9)	2,000 (8.9)	5,820 (25.9)	N/A	4,260 (19.0)	9,640 (42.9)	N/A	8,260 (36.7)	13,745 (61.1)	18,570 (82.6)	6,230 (27.7)	11,055 (49.2)
Modification factor for tension in uncracked concrete	$\psi_{c,N}$	-	1.25		1.25			1.25		1.25			1.25				1.25	
Modification factor for tension in cracked concrete	$\psi_{c,N}$	-	1.0		1.0			1.0		1.0			1.0				1.0	
Strength reduction factor ϕ for tension, steel failure of insert ^{3,5}	ϕ	-	0.65		0.65			0.65		0.65			0.65				0.65	
Strength reduction factor ϕ for shear, steel failure of insert ^{3,5}	ϕ	-	0.60		0.60			0.60		0.60			0.60				0.60	
Effectiveness factor cracked ⁴	k_{cr}	-	24		24			24		24			24				24	
Coefficient for pryout strength	k_{cp}	-	1.0		1.0			1.0		1.0			2.0				2.0	
Strength reduction factor ϕ for tension, concrete failure modes, Condition B ^{3,5}	ϕ	-	0.70		0.70			0.70		0.70			0.70				0.70	
Strength reduction factor ϕ for shear, concrete failure modes, Condition B ^{3,5}	ϕ	-	0.70		0.70			0.70		0.70			0.70				0.70	
Concrete pullout, uncracked	$N_{p,uncr}$	-	NA		NA			NA		NA			NA				NA	
Concrete pullout, cracked	$N_{p,cr}$	-	NA		NA			NA		NA			NA				NA	

For **SI**: 1 inch = 25.4 mm. For **pound-inch units**: 1 mm = 0.03937 inches.

¹ Installation must comply with Sections 4.1.11 and 4.3, and Figures 1 and 2 of this report.

² Values are for the insert only. The design professional is responsible for checking threaded rod or bolt strength in tension, shear, and combined tension and shear, as applicable.

³ See ACI 318-19 17.5.3 or ACI 318-14 17.3.3, as applicable.

⁴ See ACI 318-19 17.6.2.2 or ACI 318-14 17.4.2.2, as applicable.

⁵ For use with load combinations of ACI 318 (-19, -14) Section 5.3, as applicable. Condition B applies where supplementary reinforcement in conformance with ACI 318-19 17.5.3 or ACI 318-14 17.3.3, as applicable, is not provided. For cases where the presence of supplementary reinforcement can be verified, the strength reduction factors associated with Condition A may be used.

⁶ Only threaded rod ASTM A193 Grade B7, ASTM A325, or ASTM F1554 Grade 105 is permitted to be used for the applications resisting shear, seismic shear, or seismic tension loads.

⁷ Inserts must be installed in concrete with a minimum compressive strength f'_c of 2,500 psi.

TABLE 3B—HILTI KCC-WF AND KCCM-WF CAST-IN INSERT DESIGN INFORMATION^{1,6}

DESIGN INFORMATION	SYMBOL	UNITS	KCC-WF	KCC-WF	KCCM-WF		KCCM-WF	
			$\frac{3}{8}$ "	$\frac{1}{2}$ "	$\frac{1}{4}$ "- $\frac{3}{8}$ "	$\frac{3}{8}$ "	$\frac{3}{8}$ "	$\frac{1}{2}$ "
Effective Embedment	h_{ef}	in. (mm)	1.63 (41)	2.04 (52)	2.04 (52)		2.25 (57)	
Outside anchor diameter	d_a	in. (mm)	0.67 (17)	0.87 (22.1)	0.89 (22.6)		1.05 (26.6)	
Nominal rod diameter	-	in.	$\frac{3}{8}$ "	$\frac{1}{2}$ "	$\frac{1}{4}$ "	$\frac{3}{8}$ "	$\frac{3}{8}$ "	$\frac{1}{2}$ "
Nominal steel strength in tension as governed by the insert ²	$N_{sa,insert}$	lb (kN)	4,040 (18.0)	5,410 (24.1)	8,990 (40.0)		11,240 (50.0)	
Nominal seismic steel strength in tension as governed by the insert ²	$N_{sa,insert,eq}$	lb (kN)	4,040 (18.0)	5,410 (24.1)	8,990 (40.0)		11,240 (50.0)	
Nominal steel strength in shear as governed by the insert ²	$V_{sa,insert}$	lb (kN)	4,950 (22.0)	5,565 (24.8)	N/A	4,790 (21.3)	3,220 (14.3)	9,370 (41.7)
Nominal seismic steel strength in shear as governed by the insert ²	$V_{sa,insert,eq}$	lb (kN)	4,950 (22.0)	5,565 (24.8)	N/A	4,760 (21.2)	2,005 (8.9)	7,280 (32.4)
Modification factor for tension in uncracked concrete	$\psi_{c,N}$	-	1.25					
Modification factor for tension in cracked concrete	$\psi_{c,N}$	-	1.0					
Strength reduction factor ϕ for tension, steel failure of insert ^{3,5}	ϕ	-	0.65					
Strength reduction factor ϕ for shear, steel failure of insert ^{3,5}	ϕ	-	0.60					
Effectiveness factor cracked ⁴	k_{cr}	-	24					
Coefficient for pryout strength	k_{cp}	-	1.0					
Strength reduction factor ϕ for tension, concrete failure modes, Condition B ^{3,5}	ϕ	-	0.70					
Strength reduction factor ϕ for shear, concrete failure modes, Condition B ^{3,5}	ϕ	-	0.70					
Concrete pullout, uncracked	$N_{p,uncr}$	-	NA					
Concrete pullout, cracked	$N_{p,cr}$	-	NA					

For SI: 1 inch = 25.4 mm. For pound-inch units: 1 mm = 0.03937 inches.

¹ Installation must comply with Sections 4.1.11 and 4.3, and Figures 1 and 2 of this report.

² Values are for the insert only. The design professional is responsible for checking threaded rod or bolt strength in tension, shear, and combined tension and shear, as applicable.

³ See ACI 318-19 17.5.3 or ACI 318-14 17.3.3, as applicable.

⁴ See ACI 318-19 17.6.2.2 or ACI 318-14 17.4.2.2, as applicable.

⁵ For use with load combinations of ACI 318 (-19, -14) Section 5.3, as applicable. Condition B applies where supplementary reinforcement in conformance with ACI 318-19 17.5.3 or ACI 318-14 17.3.3, as applicable, is not provided. For cases where the presence of supplementary reinforcement can be verified, the strength reduction factors associated with Condition A may be used.

⁶ Inserts must be installed in concrete with a minimum compressive strength f'_c of 2,500 psi.

TABLE 4A—HILTI KCM-MD SP INSERT DESIGN INFORMATION^{1,4}

DESIGN INFORMATION	SYMBOL	UNITS	KCM-MD SP 1/4"-3/8"		KCM-MD SP 1/4"-3/8"-1/2"			KCM-MD SP 3/8"-1/2"		KCM-MD SP 3/8"-1/2"-5/8"			KCM-MD SP 5/8"-3/4"	
			1/4"	3/8"	1/4"	3/8"	1/2"	3/8"	1/2"	3/8"	1/2"	5/8"	5/8"	3/4"
Effective embedment	h_{ef}	in. (mm)	1.76 (45)		2.00 (51)			2.00 (51)		2.50 (64)			2.50 (64)	
Outside anchor diameter	d_a	in. (mm)	0.51 (13)		0.67 (17)			0.67 (17)		0.87 (22.1)			1.00 (25)	
Nominal rod diameter	-	-	1/4"	3/8"	1/4"	3/8"	1/2"	3/8"	1/2"	3/8"	1/2"	5/8"	5/8"	3/4"
Strength reduction factor for tension, steel failure ⁵	ϕ	-	0.65		0.65			0.65		0.65			0.65	
Strength reduction factor for shear, steel failure ⁵	ϕ	-	0.60		0.60			0.60		0.60			0.60	
Nominal steel strength in tension as governed by the insert ²	$N_{sa,insert}$	lb (kN)	8,300 (37)		12,365 (55.0)			12,365 (55.0)		12,320 (55)			22,500 (100.1)	
Nominal seismic steel strength in tension as governed by the insert ²	$N_{sa,insert,eq}$	lb (kN)	N/A	8,300 (37)	N/A	12,365 (55.0)	12,365 (55.0)	12,365 (55.0)	12,365 (55.0)	N/A	12,320 (55)	12,320 (55)	22,500 (100.1)	22,500 (100.1)
Installations in upper flute of metal deck (i.e. W-deck and B-deck) according to Figures 5A														
Nominal pullout resistance, uncracked concrete ^{3,6}	$N_{p,deck,uncr}$	lb (kN)	4,155 (18)		5,160 (23)			5,160 (23)		6,540 (29)			6,540 (29)	
Nominal pullout resistance, cracked concrete ^{3,6}	$N_{p,deck,cr}$	lb (kN)	3,325 (15)		4,130 (18)			4,130 (18)		5,230 (23)			5,230 (23)	
Nominal steel shear strength of single insert in the soffit of concrete on metal deck, upper flute ²	$V_{sa,deck}$	lb (kN)	N/A	4,685 (21)	N/A	3,470 (15.4)	8,825 (39)	3,325 (14.8)	8,825 (39)	N/A	6,085 (27.1)	11,970 (53)	10,385 (46.2)	13,760 (61)
Nominal steel shear strength of single insert in the soffit of concrete on metal deck, seismic, upper flute ²	$V_{sa,deck,eq}$	lb (kN)	N/A	4,685 (21)	N/A	2,085 (9.3)	8,825 (39)	2,000 (8.9)	8,825 (39)	N/A	4,260 (19.0)	11,970 (53)	6,230 (27.7)	13,760 (61)
Installations in lower flute of metal deck (i.e. W-deck) according to Figures 5B														
Nominal pullout resistance, uncracked concrete ^{3,6}	$N_{p,deck,uncr}$	lb (kN)	2,000 (9)		2,640 (12)			2,640 (12)		3,030 (13)			3,030 (13)	
Nominal pullout resistance, cracked concrete ^{3,6}	$N_{p,deck,cr}$	lb (kN)	1,600 (7)		2,115 (9)			2,115 (9)		2,425 (11)			2,425 (11)	
Nominal steel shear strength of single insert in the soffit of concrete on metal deck, lower flute ²	$V_{sa,deck}$	lb (kN)	N/A	3,435 (15)	N/A	3,325 (14.8)	4,185 (19)	3,325 (14.8)	4,185 (19)	N/A	5,300 (23.6)	5,440 (24)	4,690 (20.9)	5,440 (24)
Nominal steel shear strength of single insert in the soffit of concrete on metal deck, seismic, lower flute ²	$V_{sa,deck,eq}$	lb (kN)	N/A	3,435 (15)	N/A	2,000 (8.9)	4,185 (19)	2,000 (8.9)	4,185 (19)	N/A	4,260 (19.0)	5,440 (24)	4,690 (20.9)	5,440 (24)
Installations in lower flute of metal deck (i.e. B-deck) according to Figures 5C														
Nominal pullout resistance, uncracked concrete ^{3,6}	$N_{p,deck,uncr}$	lb (kN)	865 (4)		905 (4)			905 (4)		990 (4.4)			N/A	
Nominal pullout resistance, cracked concrete ^{3,6}	$N_{p,deck,cr}$	lb (kN)	690 (3)		725 (3)			725 (3)		790 (3.5)				
Nominal steel shear strength of single insert in the soffit of concrete on metal deck, lower flute ²	$V_{sa,deck}$	lb (kN)	N/A	3,155 (14)	N/A	N/A	3,965 (18)	N/A	3,965 (18)	N/A	N/A	5,580 (24.8)		
Nominal steel shear strength of single insert in the soffit of concrete on metal deck, seismic, lower flute ²	$V_{sa,deck,eq}$	lb (kN)	N/A	3,155 (14)	N/A	N/A	3,965 (18)	N/A	3,965 (18)	N/A	N/A	5,022 (22.3)		

For **SI**: 1 inch = 25.4 mm. For **pound-inch** units: 1 mm = 0.03937 inch.

¹ Concrete must be normal-weight or sand-lightweight concrete with compressive strengths greater than 3,000 psi. Installation must comply with Sections 4.1.11 and 4.3 and Figures 5A, 5B, and 5C of this report.

² The design strength must be in accordance with ACI 318 (-19, -14) Chapter 17 and Section 4.1 of this report. Values shown in the table are for the inserts only. The design professional is responsible for checking threaded rod or bolt strength in tension, shear, and combined tension and shear, as applicable.

³ Evaluation of concrete breakout capacity in accordance with ACI 318-19 17.6.2, 17.7.2 and 17.7.3 or ACI 318-14 17.4.2, 17.5.2, and 17.5.3, as applicable, is not required for anchors installed in the deck soffit.

⁴ Axial spacing for KCM-MD inserts along the lower flute length shall be minimum $3h_{ef}$.

⁵ See ACI 318-19 17.5.3 or ACI 318-14 17.3.3, as applicable.

⁶ The characteristic pullout resistance for concrete compressive strengths greater than 3,000 psi may be increased by multiplying the value in the table by $(f_c/3,000)^{1/2}$ for psi or $(f_c/20.7)^{1/2}$ for MPa.

TABLE 4B—HILTI KCM-MD LP INSERT DESIGN INFORMATION^{1,4}

DESIGN INFORMATION	SYMBOL	UNITS	KCM-MD LP 1/4"-3/8"		KCM-MD LP 1/4"-3/8"-1/2"			KCM-MD LP 3/8"-1/2"		KCM-MD LP 3/8"-1/2"-5/8"			KCM-MD LP 5/8"-3/4"	
Effective embedment	h_{ef}	in. (mm)	1.76 (45)		2.00 (51)			2.00 (51)		2.50 (64)			2.50 (64)	
Outside anchor diameter	d_a	in. (mm)	0.51 (13)		0.67 (17)			0.67 (17)		0.87 (22.1)			1.00 (25)	
Nominal rod diameter	-	-	1/4"	3/8"	1/4"	3/8"	1/2"	3/8"	1/2"	3/8"	1/2"	5/8"	5/8"	3/4"
Strength reduction factor for tension, steel failure ⁵	ϕ	-	0.65		0.65			0.65		0.65			0.65	
Strength reduction factor for shear, steel failure ⁵	ϕ	-	0.60		0.60			0.60		0.60			0.60	
Nominal steel strength in tension as governed by the insert ²	$N_{sa,insert}$	lb (kN)	8,300 (37)		12,365 (55.0)			12,365 (55.0)		12,320 (55)			22,500 (100.1)	
Nominal seismic steel strength in tension as governed by the insert ²	$N_{sa,insert,eq}$	lb (kN)	N/A	8,300 (37)	N/A	12,365 (55.0)	12,365 (55.0)	12,365 (55.0)	12,365 (55.0)	N/A	12,320 (55)	12,320 (55)	22,500 (100.1)	22,500 (100.1)
Installations in upper flute of metal deck (i.e. W-deck and B-deck) according to Figures 5A														
Nominal pullout resistance, uncracked concrete ^{3,6}	$N_{p,deck,uncr}$	lb (kN)	4,155 (18)		5,160 (23)			5,160 (23)		6,540 (29)			6,540 (29)	
Nominal pullout resistance, cracked concrete ^{3,6}	$N_{p,deck,cr}$	lb (kN)	3,325 (15)		4,130 (18)			4,130 (18)		5,230 (23)			5,230 (23)	
Nominal steel shear strength of single insert in the soffit of concrete on metal deck, upper flute ²	$V_{sa,deck}$	lb (kN)	N/A	4,685 (21)	N/A	3,470 (15.4)	8,825 (39)	3,325 (14.8)	8,825 (39)	N/A	6,085 (27.1)	11,970 (53)	10,385 (46.2)	13,760 (61)
Nominal steel shear strength of single insert in the soffit of concrete on metal deck, seismic, upper flute ²	$V_{sa,deck,eq}$	lb (kN)	N/A	4,685 (21)	N/A	2,085 (9.3)	8,825 (39)	2,000 (8.9)	8,825 (39)	N/A	4,260 (19.0)	11,970 (53)	6,230 (27.7)	13,760 (61)
Installations in lower flute of metal deck (i.e. W-deck) according to Figures 5B														
Nominal pullout resistance, uncracked concrete ^{3,6}	$N_{p,deck,uncr}$	lb (kN)	6,995 (31.1)		6,995 (31.1)			6,995 (31.1)		9,375 (41.7)			9,375 (41.7)	
Nominal pullout resistance, cracked concrete ^{3,6}	$N_{p,deck,cr}$	lb (kN)	5,595 (24.9)		5,595 (24.9)			5,595 (24.9)		7,500 (33.4)			7,500 (33.4)	
Nominal steel shear strength of single insert in the soffit of concrete on metal deck, lower flute ²	$V_{sa,deck}$	lb (kN)	N/A	5,405 (24.0)	N/A	3,325 (14.8)	6,645 (30)	3,325 (14.8)	6,645 (30)	N/A	4,040 (18.0)	7,710 (34.3)	4,690 (20.9)	7,710 (34)
Nominal steel shear strength of single insert in the soffit of concrete on metal deck, seismic, lower flute ²	$V_{sa,deck,eq}$	lb (kN)	N/A	5,405 (24.0)	N/A	2,000 (8.9)	6,645 (30)	2,000 (8.9)	6,645 (30)	N/A	4,040 (18.0)	7,710 (34.3)	4,690 (20.9)	7,710 (34)
Installations in lower flute of metal deck (i.e. B-deck) according to Figures 5C														
Nominal pullout resistance, uncracked concrete ^{3,6}	$N_{p,deck,uncr}$	lb (kN)	4,155 (18)		5,160 (23)			5,160 (23)		6,540 (29.1)			6,540 (31)	
Nominal pullout resistance, cracked concrete ^{3,6}	$N_{p,deck,cr}$	lb (kN)	3,325 (15)		4,130 (18)			4,130 (18)		5,230 (23.3)			5,230 (23)	
Nominal steel shear strength of single insert in the soffit of concrete on metal deck, lower flute ²	$V_{sa,deck}$	lb (kN)	N/A	4,815 (21.4)	N/A	N/A	7,540 (35)	N/A	7,540 (35)	N/A	N/A	9,585 (42.6)	N/A	11,920 (56)
Nominal steel shear strength of single insert in the soffit of concrete on metal deck, seismic, lower flute ²	$V_{sa,deck,eq}$	lb (kN)	N/A	4,815 (21.4)	N/A	N/A	7,540 (35)	N/A	7,540 (35)	N/A	N/A	9,585 (42.6)	N/A	11,920 (56)
Installations over flute incline of metal deck (i.e. W-deck) according to Figures 5D														
Nominal pullout resistance, uncracked concrete ^{3,6}	$N_{p,deck,uncr}$	lb (kN)	4,155 (18)		5,160 (23)			5,160 (23)		6,540 (31)			6,540 (31)	
Nominal pullout resistance, cracked concrete ^{3,6}	$N_{p,deck,cr}$	lb (kN)	3,325 (15)		4,130 (18)			4,130 (18)		5,230 (23)			5,230 (23)	
Nominal steel shear strength of single insert in the soffit of concrete on metal deck, over flute incline ²	$V_{sa,deck}$	lb (kN)	N/A	1,720 (7.7)	N/A	N/A	4,445 (20)	N/A	4,445 (20)	N/A	N/A	9,975 (44)	N/A	9,975 (44)
Nominal steel shear strength of single insert in the soffit of concrete on metal deck, seismic, over flute incline ²	$V_{sa,deck,eq}$	lb (kN)	N/A	1,720 (7.7)	N/A	N/A	3,555 (16)	N/A	3,555 (16)	N/A	N/A	5,615 (25)	N/A	9,475 (42)

For **SI**: 1 inch = 25.4 mm. For **pound-inch** units: 1 mm = 0.03937 inch.

¹ Concrete must be normal-weight or sand-lightweight concrete with compressive strengths greater than 3,000 psi. Installation must comply with Sections 4.1.11 and 4.3 and Figures 5A, 5B, 5C, and 5D of this report.

² The design strength must be in accordance with ACI 318 (-19, -14) Chapter 17 and Section 4.1 of this report. Values shown in the table are for the inserts only. The design professional is responsible for checking threaded rod or bolt strength in tension, shear, and combined tension and shear, as applicable.

³ Evaluation of concrete breakout capacity in accordance with ACI 318-19 17.6.2, 17.7.2 and 17.7.3 or ACI 318-14 17.4.2, 17.5.2, and 17.5.3, as applicable, is not required for anchors installed in the deck soffit.

⁴ Axial spacing for KCM-MD inserts along the lower flute length shall be minimum $3h_{ef}$.

⁵ See ACI 318-19 17.5.3 or ACI 318-14 17.3.3, as applicable.

⁶ The characteristic pullout resistance for concrete compressive strengths greater than 3,000 psi may be increased by multiplying the value in the table by $(f_c/3,000)^{1/2}$ for psi or $(f_c/20.7)^{1/2}$ for MPa.

TABLE 4C—HILTI KCC-MD SP, KCC-MD LP, KCCM-MD SP, AND KCCM-MD LP INSERT DESIGN INFORMATION^{1,4}

DESIGN INFORMATION	SYMBOL	UNITS	KCC-MD SP 3/8"	KCC-MD SP 1/2"	KCC-MD LP 3/8"	KCC-MD LP 1/2"	KCCM-MD SP 1/4"-3/8"		KCCM-MD SP 3/8"-1/2"		KCCM-MD LP 1/4"-3/8"		KCCM-MD LP 3/8"-1/2"		
Effective embedment	h_{ef}	in. (mm)	2.00 (51)	2.50 (64)	2.00 (51)	2.50 (64)	2.33 (51)		2.58 (64)		2.33 (51)		2.58 (64)		
Outside anchor diameter	d_a	in. (mm)	0.67 (17)	0.87 (22.1)	0.67 (17)	0.87 (22.1)	0.89 (22.6)		1.05 (26.6)		0.89 (22.6)		1.05 (26.6)		
Nominal rod diameter	-	-	3/8"	1/2"	3/8"	1/2"	1/4"	3/8"	3/8"	1/2"	1/4"	3/8"	3/8"	1/2"	
Strength reduction factor for tension, steel failure ⁵	ϕ	-	0.65												
Strength reduction factor for shear, steel failure ⁵	ϕ	-	0.60												
Nominal steel strength in tension as governed by the insert ²	$N_{sa,insert}$	lb (kN)	4,040 (18.0)	5,410 (24.1)	4,040 (18.0)	5,410 (24.1)	8,990 (40.0)		11,240 (50.0)		8,990 (40.0)		11,240 (50.0)		
Nominal seismic steel strength in tension as governed by the insert ²	$N_{sa,insert,eq}$	lb (kN)	4,040 (18.0)	5,410 (24.1)	4,040 (18.0)	5,410 (24.1)	N/A	8,990 (40.0)	11,240 (50.0)	N/A	8,990 (40.0)	11,240 (50.0)	N/A	11,240 (50.0)	
Installations in upper flute of metal deck (i.e. W-deck and B-deck) according to Figures 5A															
Nominal pullout resistance, uncracked concrete ^{3,6}	$N_{p,deck,uncr}$	lb (kN)	5,160 (23)	6,540 (29)	5,160 (23)	6,540 (29)	5,160 (23)		6,540 (29)		5,160 (23)		6,540 (29)		
Nominal pullout resistance, cracked concrete ^{3,6}	$N_{p,deck,cr}$	lb (kN)	4,130 (18)	5,230 (23)	4,130 (18)	5,230 (23)	4,130 (18)		5,230 (23)		4,130 (18)		5,230 (23)		
Nominal steel shear strength of single insert in the soffit of concrete on metal deck, upper flute ²	$V_{sa,deck}$	lb (kN)	4,685 (21)	5,565 (24.8)	4,685 (21)	5,565 (24.8)	N/A	4,685 (21)	3,220 (14.3)	5,565 (24.8)	N/A	4,685 (21)	3,220 (14.3)	5,565 (24.8)	
Nominal steel shear strength of single insert in the soffit of concrete on metal deck, seismic, upper flute ²	$V_{sa,deck,eq}$	lb (kN)	4,685 (21)	5,565 (24.8)	4,685 (21)	5,565 (24.8)	N/A	4,685 (21)	2,005 (8.9)	5,565 (24.8)	N/A	4,685 (21)	2,005 (8.9)	5,565 (24.8)	
Installations in lower flute of metal deck (i.e. W-deck) according to Figures 5B															
Nominal pullout resistance, uncracked concrete ^{3,6}	$N_{p,deck,uncr}$	lb (kN)	2,640 (12)	3,030 (13)	6,995 (31.1)	9,375 (41.7)	2,640 (12)		3,030 (13)		6,995 (31.1)		9,375 (41.7)		
Nominal pullout resistance, cracked concrete ^{3,6}	$N_{p,deck,cr}$	lb (kN)	2,115 (9)	2,425 (11)	5,595 (24.9)	7,500 (33.4)	2,115 (9)		2,425 (11)		5,595 (24.9)		7,500 (33.4)		
Nominal steel shear strength of single insert in the soffit of concrete on metal deck, lower flute ²	$V_{sa,deck}$	lb (kN)	3,435 (15)	4,185 (19)	4,950 (22)	5,565 (24.8)	N/A	3,435 (15)	3,220 (14.3)	4,185 (19)	N/A	4,790 (21.3)	3,220 (14.3)	5,565 (24.8)	
Nominal steel shear strength of single insert in the soffit of concrete on metal deck, seismic, lower flute ²	$V_{sa,deck,eq}$	lb (kN)	3,435 (15)	4,185 (19)	4,950 (22)	5,565 (24.8)	N/A	3,435 (15)	2,005 (8.9)	4,185 (19)	N/A	4,760 (21.2)	2,005 (8.9)	5,565 (24.8)	
Installations in lower flute of metal deck (i.e. B-deck) according to Figures 5C															
Nominal pullout resistance, uncracked concrete ^{3,6}	$N_{p,deck,uncr}$	lb (kN)	905 (4.4)	990 (4.4)	5,160 (23.0)	6,540 (29.1)	905 (4.4)		990 (4.4)		5,160 (23.0)		6,540 (29.1)		
Nominal pullout resistance, cracked concrete ^{3,6}	$N_{p,deck,cr}$	lb (kN)	725 (3.5)	790 (3.5)	4,130 (18.4)	5,230 (23.3)	725 (3.2)		790 (3.5)		4,130 (18.4)		5,230 (23.3)		
Nominal steel shear strength of single insert in the soffit of concrete on metal deck, lower flute ²	$V_{sa,deck}$	lb (kN)	3,155 (14.0)	3,965 (17.6)	4,815 (21.4)	5,565 (24.8)	N/A	3,155 (14)	3,155 (14)	3,965 (18)	N/A	4,790 (21.3)	3,220 (14.3)	5,565 (24.8)	
Nominal steel shear strength of single insert in the soffit of concrete on metal deck, seismic, lower flute ²	$V_{sa,deck,eq}$	lb (kN)	3,155 (14.0)	3,965 (17.6)	4,815 (21.4)	5,565 (24.8)	N/A	3,155 (14)	2,005 (8.9)	3,965 (18)	N/A	4,760 (21.2)	2,005 (8.9)	5,565 (24.8)	
Installations over flute incline of metal deck (i.e. W-deck) according to Figures 5D															
Nominal pullout resistance, uncracked concrete ^{3,6}	$N_{p,deck,uncr}$	lb (kN)	N/A			5,160 (23.0)	6,540 (29.1)	N/A				5,160 (23.0)		6,540 (29.1)	
Nominal pullout resistance, cracked concrete ^{3,6}	$N_{p,deck,cr}$	lb (kN)				4,130 (18.4)	5,230 (23.3)					4,130 (18.4)		5,230 (23.3)	
Nominal steel shear strength of single insert in the soffit of concrete on metal deck, over flute incline ²	$V_{sa,deck}$	lb (kN)				1,720 (7.7)	4,445 (19.8)					1,720 (7.7)		4,445 (19.8)	
Nominal steel shear strength of single insert in the soffit of concrete on metal deck, seismic, over flute incline ²	$V_{sa,deck,eq}$	lb (kN)				1,720 (7.7)	3,555 (15.8)					1,720 (7.7)		3,555 (15.8)	

For **SI**: 1 inch = 25.4 mm. For **pound-inch** units: 1 mm = 0.03937 inch.

¹ Concrete must be normal-weight or sand-lightweight concrete with compressive strengths greater than 3,000 psi. Installation must comply with Sections 4.1.11 and 4.3 and Figures 5A, 5B, 5C, and 5D of this report.

² The design strength must be in accordance with ACI 318 (-19, -14) Chapter 17 and Section 4.1 of this report. Values shown in the table are for the inserts only. The design professional is responsible for checking threaded rod or bolt strength in tension, shear, and combined tension and shear, as applicable.

³ Evaluation of concrete breakout capacity in accordance with ACI 318-19 17.6.2, 17.7.2 and 17.7.3 or ACI 318-14 17.4.2, 17.5.2, and 17.5.3, as applicable, is not required for anchors installed in the deck soffit.

⁴ Axial spacing for KCC-MD inserts along the lower flute length shall be minimum $3h_{ef}$.

⁵ See ACI 318-19 17.5.3 or ACI 318-14 17.3.3, as applicable.

⁶ The characteristic pullout resistance for concrete compressive strengths greater than 3,000 psi may be increased by multiplying the value in the table by $(f' / 3,000)^{1/2}$ for psi or $(f' / 20.7)^{1/2}$ for MPa.

TABLE 5—SPECIFICATIONS AND PHYSICAL PROPERTIES OF COMMON CARBON STEEL THREADED ROD ELEMENTS ¹

Threaded rod specification	Units	Min. specified ultimate strength f_{uta}	Min. specified yield strength, 0.2 percent offset, f_{ya}	f_{uta} / f_{ya}	Elongation, min. percent ⁵	Reduction of area, min. percent	Specification for nuts ⁶
ASTM A36/A36M ² and F1554 ³ Grade 36	psi (MPa)	58,000 (400)	36,000 (248)	1.61	23	40 (50 for A36)	ASTM A194 / A563 Grade A
ASTM F1554 ³ Grade 105	psi (MPa)	125,000 (862)	105,000 (724)	1.19	15	45	ASTM A194 / A563 Grade DH
ASTM A193/A193M ⁴ Grade B7	psi (MPa)	125,000 (860)	105,000 (720)	1.19	16	50	

For SI: 1 inch = 25.4 mm, 1 psi = 0.006897 MPa. For **pound-inch** units: 1 mm = 0.03937 inch, 1 MPa = 145.0 psi.

¹ Inserts may be used in conjunction with all grades of continuously threaded carbon steels (all-thread) that comply with code reference standards and that have thread characteristics comparable with ANSI B1.1 UNC Coarse Thread Series or ANSI B1.13M M Profile Metric Coarse Thread Series. Tabulated values correspond to anchor diameters included in this report. See section 3.2.2 of this report for ductility of steel anchor elements.

² Standard Specification for Carbon Structural Steel.

³ Standard Specification for Anchor Bolts, Steel, 36, 55, and 105-ksi Yield Strength.

⁴ Standard Specification for Alloy-Steel and Stainless Steel Bolting Materials for High Temperature or High Pressure Service and Other Special Purpose Applications.

⁵ Based on 2-inch (50 mm) gauge length except ASTM A193, which are based on a gauge length of 4d.

⁶ Where nuts are applicable, nuts of the other grades and style having specified proof load stress greater than the specified grade and style are also suitable.

TABLE 6—STEEL DESIGN INFORMATION FOR COMMON THREADED ROD ELEMENTS USED WITH CONCRETE INSERTS ^{1,2,3,4}

Design Information		Symbol	Units	Nominal anchor size / Internal thread dia. (in)				
				1/4	3/8	1/2	5/8	3/4
Nominal rod diameter		d_{rod}	in. (mm)	0.250 (6.4)	0.375 (9.5)	0.500 (12.7)	0.625 (15.9)	0.75 (19.1)
Rod effective cross-sectional area		$A_{se,rod}$	in. ² (mm ²)	0.0318 (21)	0.0775 (50)	0.1419 (92)	0.2260 (146)	0.3345 (216)
ASTM A36, ASTM F1554 Gr. 36	Strength reduction factor for steel in tension ⁴	$\phi_{sa,rod,N}$	-	0.75	0.75	0.75	0.75	0.75
	Steel strength in tension	$N_{sa,rod}$	lb (kN)	1,845 (8.2)	4,495 (20.0)	8,230 (36.6)	13,110 (58.3)	19,400 (86.3)
	Steel strength in tension, seismic	$N_{sa,rod,eq}$	lb (kN)	1,845 (8.2)	4,495 (20.0)	8,230 (36.6)	13,110 (58.3)	19,400 (86.3)
	Strength reduction factor for steel in shear ⁴	$\phi_{sa,rod,V}$	-	0.65	0.65	0.65	0.65	0.65
	Steel strength in shear	$V_{sa,rod}$	lb (kN)	1,105 (4.9)	2,695 (12.0)	4,940 (22.0)	7,865 (35.0)	11,640 (51.8)
	Steel strength in shear, seismic	$V_{sa,rod,eq}$	lb (kN)	775 (3.4)	1,885 (8.4)	3,460 (15.4)	5,505 (24.5)	8,148 (36.2)
ASTM A193 Gr. B7, F1554 Gr. 105	Strength reduction factor for steel in tension ⁴	$\phi_{sa,rod,N}$	-	0.75	0.75	0.75	0.75	0.75
	Steel strength in tension	$N_{sa,rod}$	lb (kN)	4,000 (17.7)	9,750 (43.1)	17,750 (78.9)	28,250 (125.7)	41,815 (186.0)
	Steel strength in tension, seismic	$N_{sa,rod,eq}$	lb (kN)	4,000 (17.7)	9,750 (43.1)	17,750 (78.9)	28,250 (125.7)	41,815 (186.0)
	Strength reduction factor for steel in shear ⁴	$\phi_{sa,rod,V}$	-	0.65	0.65	0.65	0.65	0.65
	Steel strength in shear	$V_{sa,rod}$	lb (kN)	2,385 (10.6)	5,815 (25.9)	10,640 (7.3)	16,950 (75.4)	25,090 (111.6)
	Steel strength in shear, seismic	$V_{sa,rod,eq}$	lb (kN)	1,680 (7.5)	4,095 (18.2)	7,455 (34.2)	11,865 (52.8)	17,563 (78.1)

For SI: 1 inch = 25.4 mm, 1 pound = 0.00445 kN. For **pound-inch** units: 1 mm = 0.03937 inch.

¹ Values provided for steel element material types, or equivalent, based on minimum specified strengths and calculated in accordance with ACI 318-19 Eq. (17.6.1.2) and Eq. (17.7.1.2b) or ACI 318-14 Eq. (17.4.1.2) and Eq. (17.5.1.2b), as applicable. $V_{sa,eq,rod}$ must be taken as $0.7V_{sa,rod}$.

² ϕN_{sa} shall be the lower of $\phi N_{sa,rod}$ or $\phi N_{sa,insert}$ for static steel strength in tension; for seismic loading, $\phi N_{sa,eq}$ shall be the lower of $\phi N_{sa,rod,eq}$ or $\phi N_{sa,insert,eq}$.

³ ϕV_{sa} shall be the lower of $\phi V_{sa,rod}$ or $\phi V_{sa,insert}$ for static steel strength in tension; for seismic loading, $\phi V_{sa,eq}$ shall be the lower of $\phi V_{sa,rod,eq}$ or $\phi V_{sa,insert,eq}$.

⁴ The strength reduction factor applies when the load combinations from the IBC or ACI 318 are used and the requirements of ACI 318-19 17.5.3 or ACI 318-14 17.3.3, as applicable, are met.

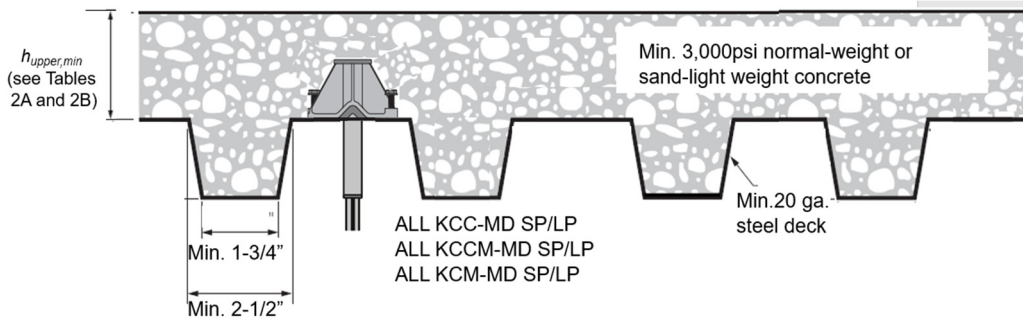

FIGURE 5A—INSTALLATION IN THE SOFFIT OF CONCRETE FILLED METAL DECK FLOOR AND ROOF ASSEMBLIES-OVER UPPER FLUTE (B-DECK AND W-DECK)

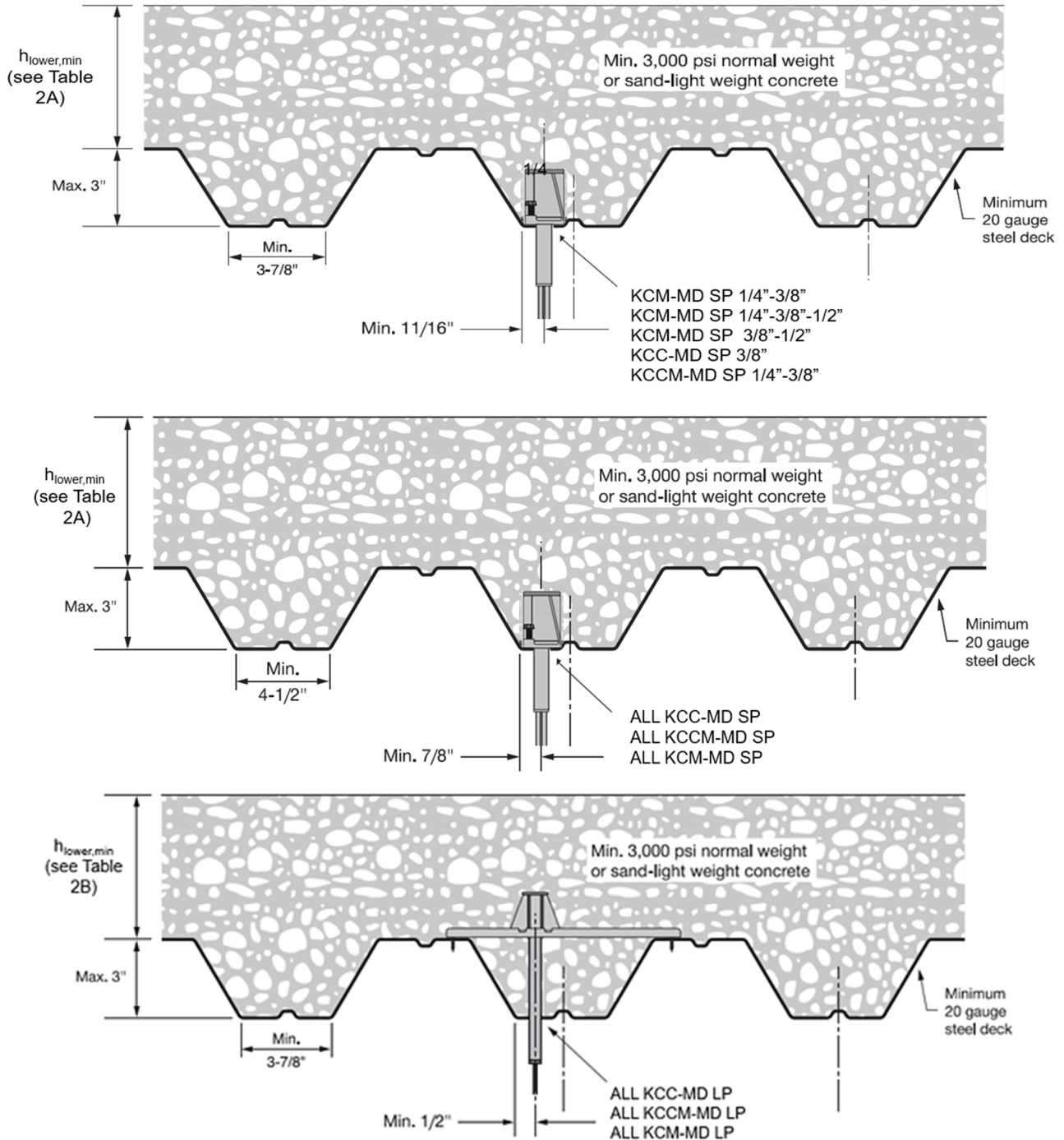

FIGURE 5B—INSTALLATION IN THE SOFFIT OF CONCRETE FILLED METAL DECK FLOOR AND ROOF ASSEMBLIES-OVER LOWER FLUTE (W-DECK)

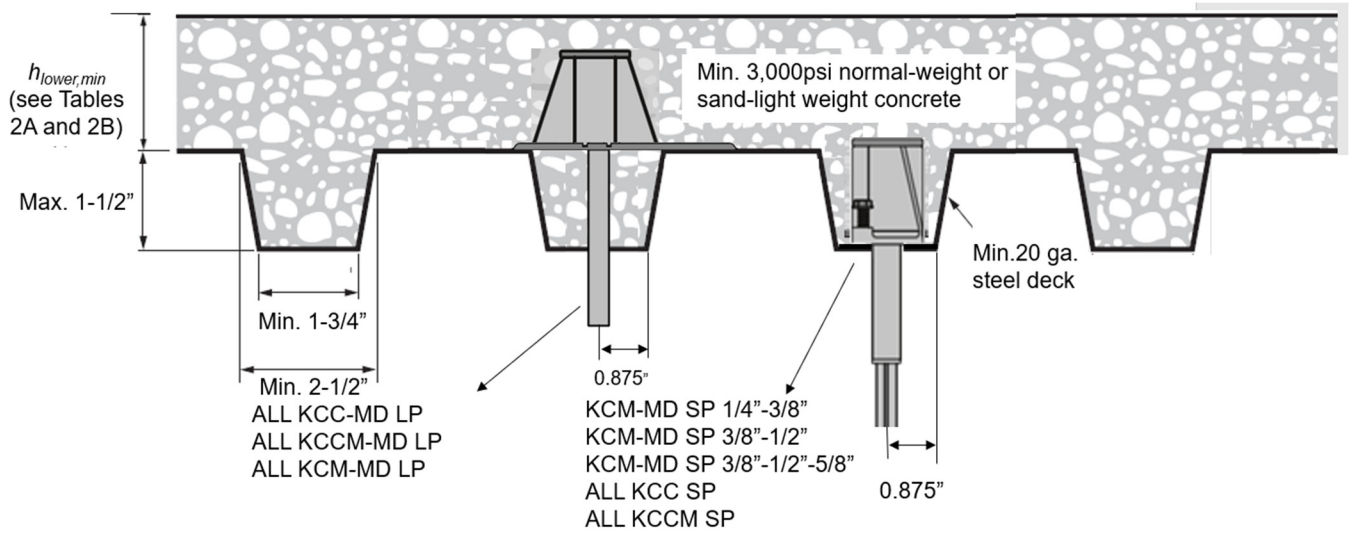

FIGURE 5C—INSTALLATION IN THE SOFFIT OF CONCRETE FILLED METAL DECK FLOOR AND ROOF ASSEMBLIES-OVER LOWER FLUTE (B-deck)

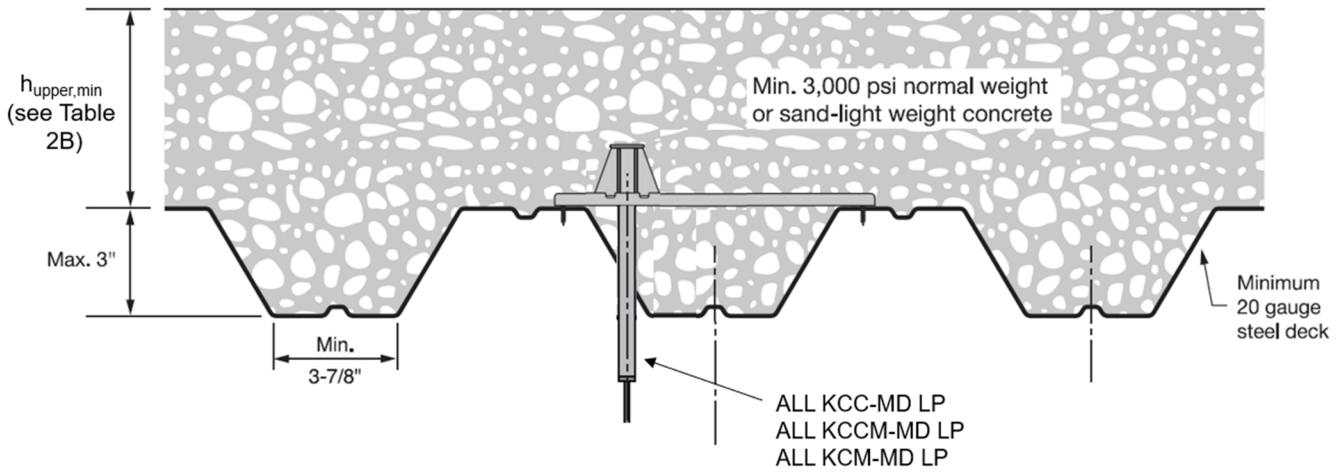

FIGURE 5D—INSTALLATION IN THE SOFFIT OF CONCRETE FILLED METAL DECK FLOOR AND ROOF ASSEMBLIES-OVER FLUTE INCLINE (W-deck)

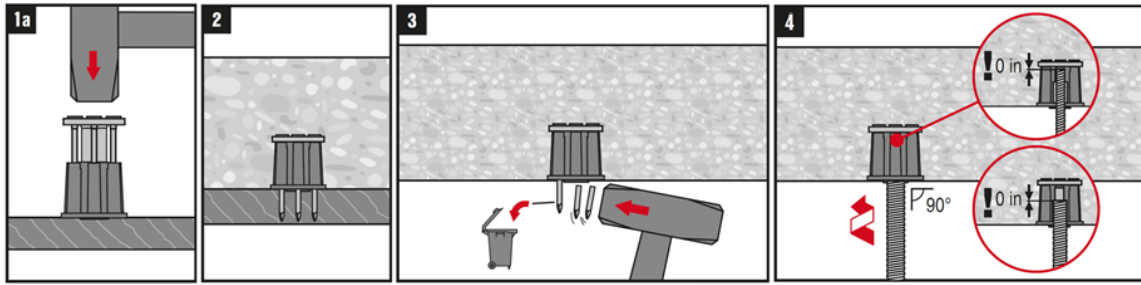

FIGURE 6—KCM-WF CONCRETE INSERTS MANUFACTURER PRINTED INSTALLATION INSTRUCTIONS (MPII)

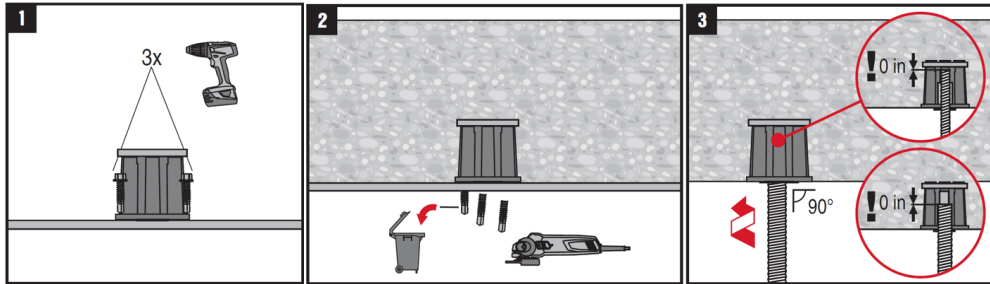

FIGURE 7—KCM-PD CONCRETE INSERTS MANUFACTURER PRINTED INSTALLATION INSTRUCTIONS (MPII)

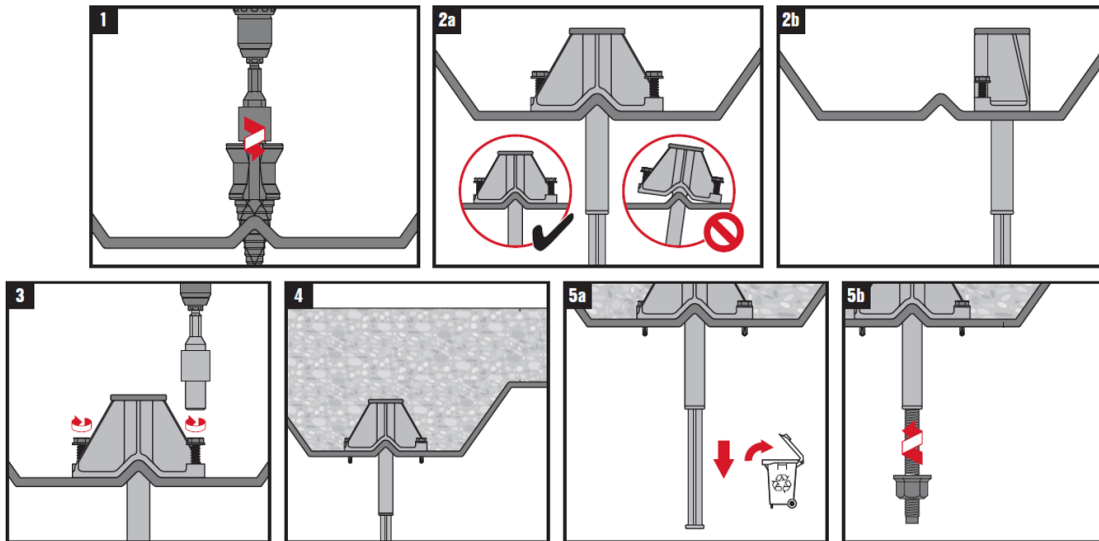

FIGURE 8—KCM-MD SP CONCRETE INSERTS MANUFACTURER PRINTED INSTALLATION INSTRUCTIONS (MPII)

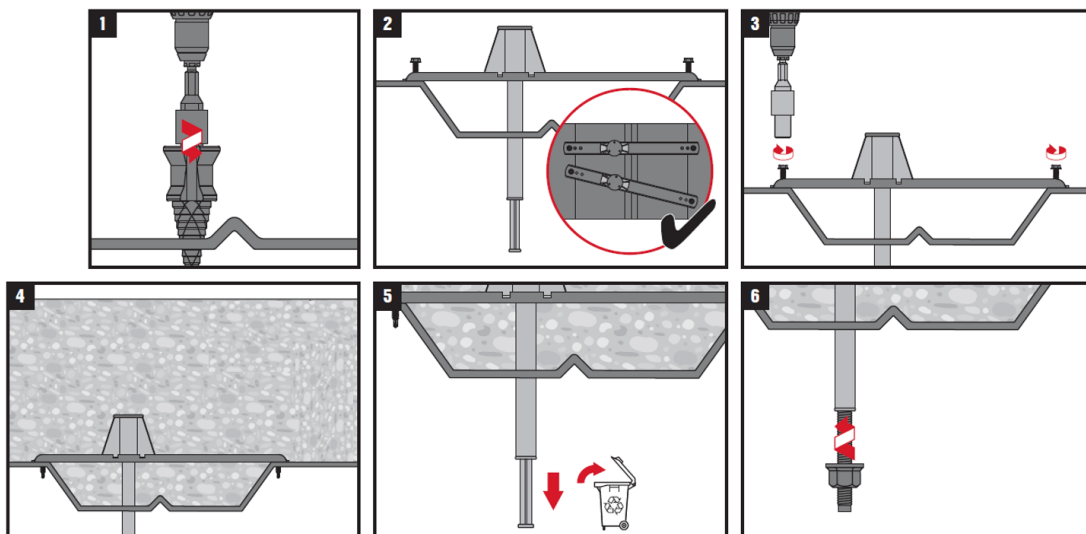

FIGURE 9—KCM-MD LP CONCRETE INSERTS MANUFACTURER PRINTED INSTALLATION INSTRUCTIONS (MPII)

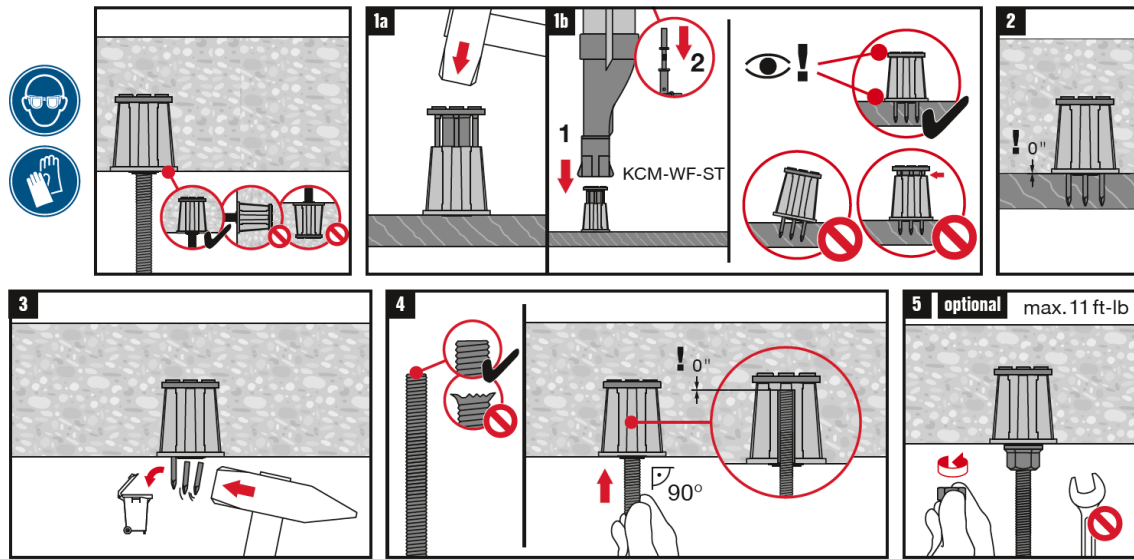

FIGURE 10—KCC-WF CONCRETE INSERTS MANUFACTURER PRINTED INSTALLATION INSTRUCTIONS (MPII)

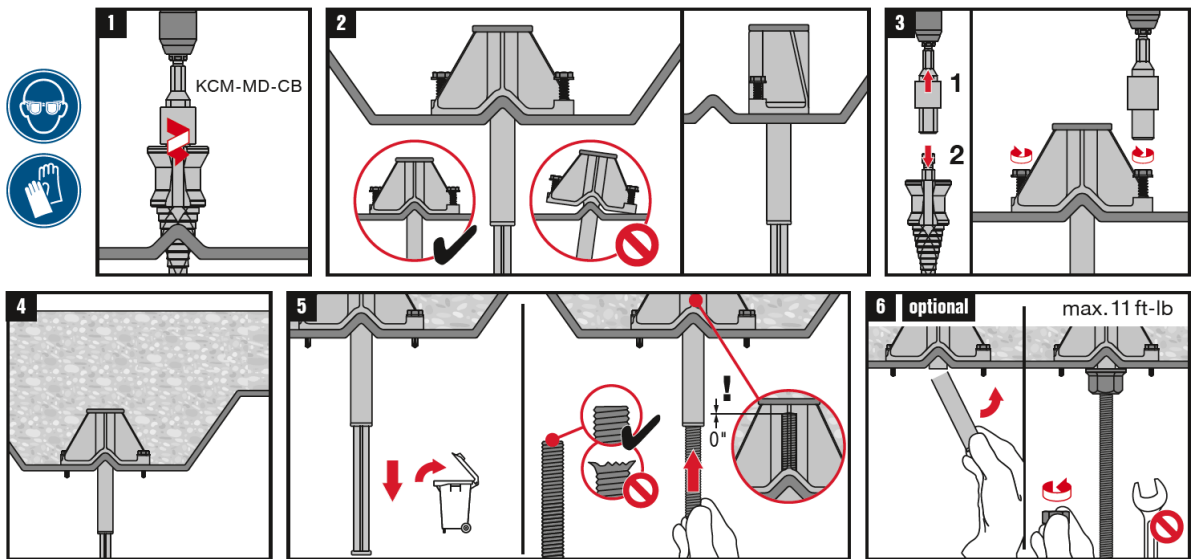

FIGURE 11—KCC-MD SP CONCRETE INSERTS MANUFACTURER PRINTED INSTALLATION INSTRUCTIONS (MPII)

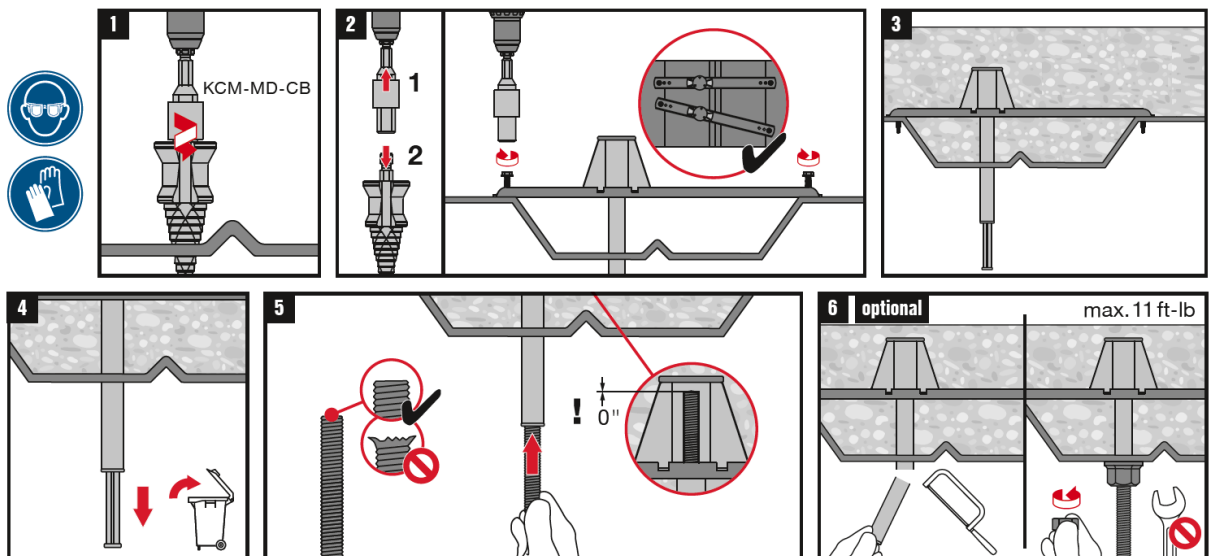

FIGURE 12—KCC-MD LP CONCRETE INSERTS MANUFACTURER PRINTED INSTALLATION INSTRUCTIONS (MPII)

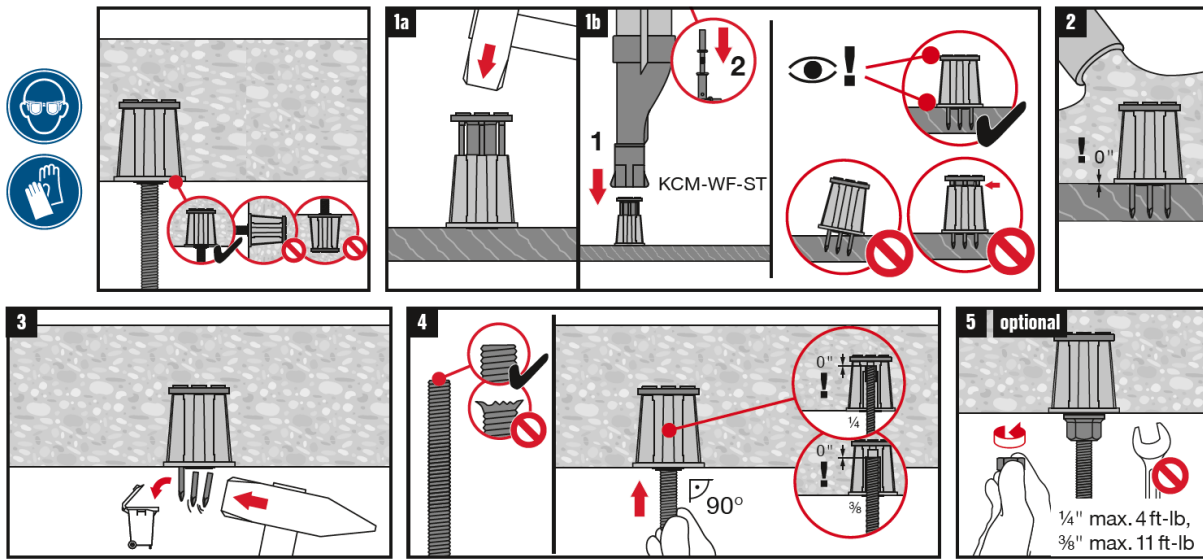

FIGURE 13—KCCM-WF CONCRETE INSERTS MANUFACTURER PRINTED INSTALLATION INSTRUCTIONS (MPII)

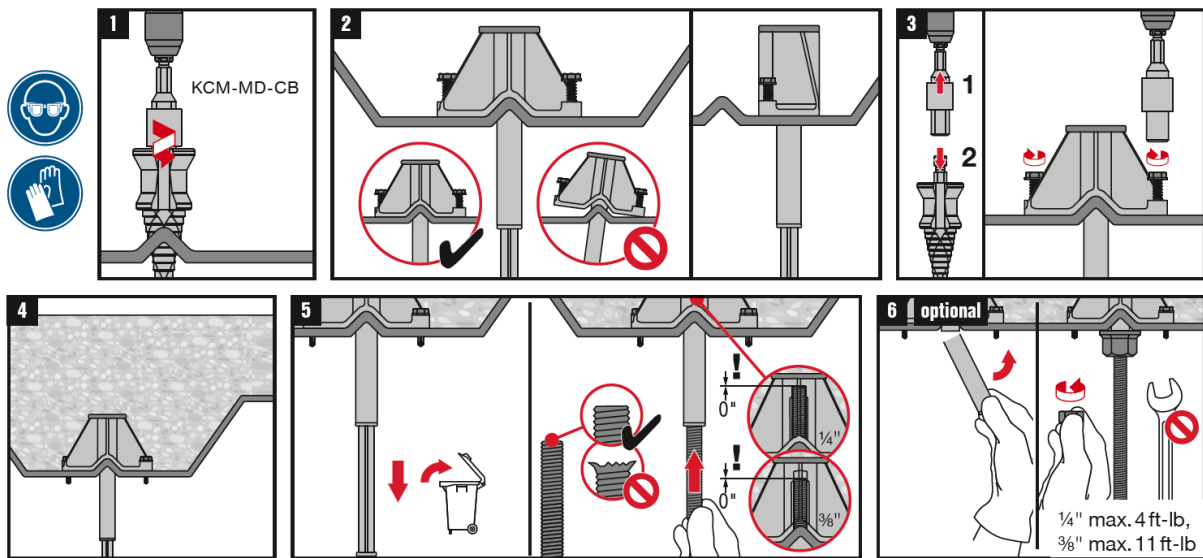

FIGURE 14—KCCM-MD SP CONCRETE INSERTS MANUFACTURER PRINTED INSTALLATION INSTRUCTIONS (MPII)

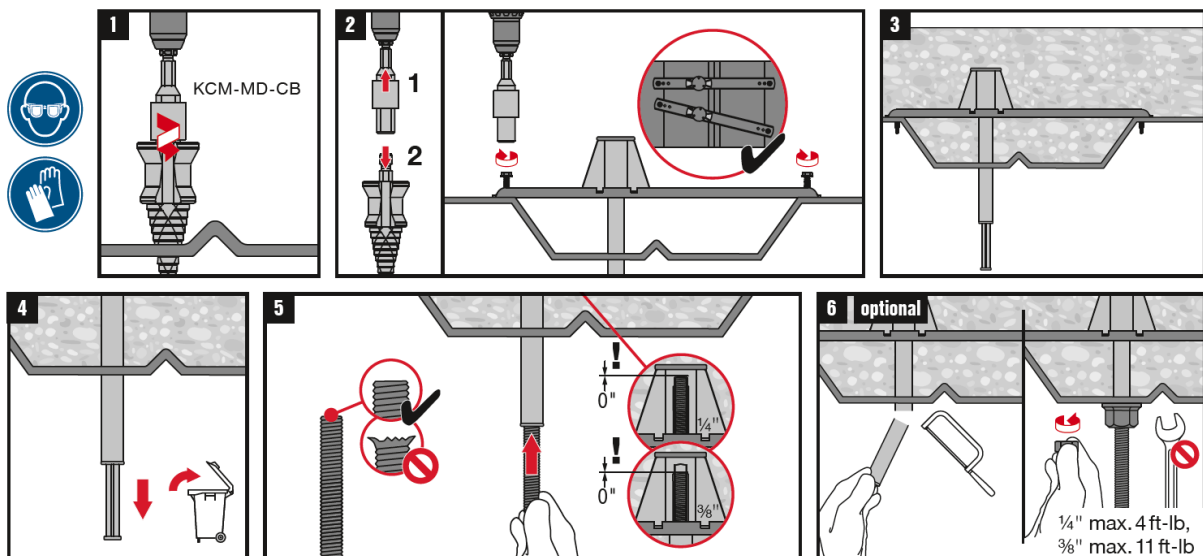

FIGURE 15—KCCM-MD LP CONCRETE INSERTS MANUFACTURER PRINTED INSTALLATION INSTRUCTIONS (MPII)

DIVISION: 03 00 00—CONCRETE**Section: 03 15 19—Cast-in Concrete Anchors****Section: 03 16 00—Concrete Anchors****REPORT HOLDER:**

HILTI, INC.

EVALUATION SUBJECT:**HILTI KCC-WF, KCC-MD, KCCM-WF, KCCM-MD, KCM-WF, KCM-PD, AND KCM-MD HEADED CAST-IN SPECIALTY INSERTS IN CRACKED AND UNCRACKED CONCRETE****1.0 REPORT PURPOSE AND SCOPE****Purpose:**

The purpose of this evaluation report supplement is to indicate that the Hilti KCC-WF, KCC-MD, KCCM-WF, KCCM-MD, KCM-WF, KCM-PD, and KCM-MD Headed Cast-In Specialty Inserts in cracked and uncracked concrete, described in ICC-ES evaluation report [ESR-4145](#), have also been evaluated for compliance with the codes noted below as adopted by the Los Angeles Department of Building and Safety (LADBS).

Applicable code editions:

- 2023 *City of Los Angeles Building Code* (LABC)
- 2023 *City of Los Angeles Residential Code* (LARC)

2.0 CONCLUSIONS

The Hilti KCC-WF, KCC-MD, KCCM-WF, KCCM-MD, KCM-WF, KCM-PD, and KCM-MD Headed Cast-In Specialty Inserts in cracked and uncracked concrete, described in Sections 2.0 through 7.0 of the evaluation report [ESR-4145](#), comply with LABC Chapter 19, and LARC, and are subject to the conditions of use described in this supplement.

3.0 CONDITIONS OF USE

The Hilti KCC-WF, KCC-MD, KCCM-WF, KCCM-MD, KCM-WF, KCM-PD, and KCM-MD Headed Cast-In Specialty Inserts described in this evaluation report supplement must comply with all of the following conditions:

- All applicable sections in the evaluation report [ESR-4145](#).
- The design, installation, conditions of use and labeling of the Hilti KCC-WF, KCC-MD, KCCM-WF, KCCM-MD, KCM-WF, KCM-PD and KCM-MD Headed Cast-In Specialty Inserts are in accordance with the 2021 *International Building Code*® (IBC) provisions noted in the evaluation report [ESR-4145](#).
- The design, installation and inspection are in accordance with additional requirements of LABC Chapters 16, 17 and City of Los Angeles Information Bulletin P/BC 2020-092, as applicable.
- Under the LARC, an engineered design in accordance with LARC Section R301.1.3 must be submitted.
- The allowable and strength design values listed in the evaluation report and tables are for the connection of the headed cast-in specialty inserts to the concrete. The connection between the headed cast-in specialty inserts and the connected members shall be checked for capacity (which may govern).

This supplement expires concurrently with the evaluation report, reissued February 2023 and revised September 2024.

DIVISION: 03 00 00—CONCRETE
Section: 03 15 19—Cast-in Concrete Anchors
Section: 03 16 00—Concrete Anchors

REPORT HOLDER:

HILTI, INC.

EVALUATION SUBJECT:

HILTI KCC-WF, KCC-MD, KCCM-WF, KCCM-MD, KCM-WF, KCM-PD, AND KCM-MD HEADED CAST-IN SPECIALTY INSERTS IN CRACKED AND UNCRACKED CONCRETE

1.0 REPORT PURPOSE AND SCOPE

Purpose:

The purpose of this evaluation report supplement is to indicate that the Hilti KCC-WF, KCC-MD, KCCM-WF, KCCM-MD, KCM-WF, KCM-PD, and KCM-MD Headed Cast-In Specialty Inserts in Cracked and Uncracked Concrete, described in ICC-ES evaluation report ESR-4145, have also been evaluated for compliance with the codes noted below.

Applicable code editions:

- 2023 Florida Building Code—Building
- 2023 Florida Building Code—Residential

2.0 CONCLUSIONS

The Hilti KCC-WF, KCC-MD, KCCM-WF, KCCM-MD, KCM-WF, KCM-PD, and KCM-MD Headed Cast-In Specialty Inserts in Cracked and Uncracked Concrete, described in Sections 2.0 through 7.0 of ICC-ES evaluation report ESR-4145, comply with the *Florida Building Code—Building* and the *Florida Building Code—Residential*, provided the design requirements are determined in accordance with the *Florida Building Code—Building* or the *Florida Building Code—Residential*, as applicable. The installation requirements noted in ICC-ES evaluation report ESR-4145 for the 2021 *International Building Code*® meet the requirements of the *Florida Building Code—Building* or the *Florida Building Code—Residential*, as applicable.

Use of the Hilti KCC-WF, KCC-MD, KCCM-WF, KCCM-MD, KCM-WF, KCM-PD, and KCM-MD Headed Cast-In Specialty Inserts in Cracked and Uncracked Concrete have also been found to be in compliance with the High-Velocity Hurricane Zone Provisions of the *Florida Building Code—Building* and *Florida Building Code—Residential* with the following condition.

- a) For anchorage of wood members, the connection subject to uplift, must be designed for no less than 700 pounds (3114 N).

For products falling under Florida Rule 61G20-3, verification that the report holder's quality-assurance program is audited by a quality-assurance entity approved by the Florida Building Commission for the type of inspections being conducted is the responsibility of an approved validation entity (or the code official, when the report holder does not possess an approval by the Commission).

This supplement expires concurrently with the evaluation report, reissued February 2023 and revised September 2024.